



## Instruction manual

# CL 3436

RESIDUAL CHLORINE - CHLORINE DIOXIDE  
DISSOLVED OZONE TRANSMITTER

### Measuring scales

2.000 ÷ 200.0 ppm  
2.000 ÷ 200.0 mg/l

### Temperature scales

-10.0 ÷ 110.0 °C  
14.0 ÷ 230.0 °F

### Option

S/N  
REP N°

Power supply: 9 ÷ 36 Vdc  
Installed firmware: R 3.0x





# INDEX

<b>1 - GENERAL WARNINGS AND INFORMATION FOR ALL USERS</b>	<b>3</b>
1.1 Warranty .....	3
1.2 After sales service .....	3
1.3 CE marking .....	3
1.4 Safety warnings .....	4
1.5 Manual revisions .....	4
<b>2 - PRODUCT OVERVIEW</b>	<b>5</b>
2.1 Functional purpose of the device .....	5
2.2 Accessories .....	5
<b>3 - INSTRUCTION MANUAL CONTENTS</b>	<b>6</b>
3.1 Symbols .....	6
3.2 How to read the instruction manual .....	6
3.2.1 Using the instrument on the plant .....	7
3.2.2 Plant maintenance staff .....	7
3.2.3 Instrument installation .....	8
<b>4 - SPECIFICATIONS AND TECHNICAL DATA</b>	<b>9</b>
4.1 Functional specification .....	9
4.2 Technical data .....	12
4.2.1 General specifications .....	12
4.2.2 Technical specifications .....	13
<b>5 - INSTALLATION</b>	<b>17</b>
5.1 Packing list .....	17
5.2 Packing and unpacking .....	17
5.3 Storage and transport .....	17
5.4 Installation of the transmitter .....	17
5.5 Installation of the sensor .....	17
5.6 Electrical installation .....	18
5.6.1 Connection of the measuring cell .....	18
5.6.2 Connection of the temperature sensor .....	19
5.6.3 Connection of the current loop .....	19
5.6.4 Connection of the logic input .....	19
5.6.5 Connection to the RS485 serial port .....	20
5.6.6 Network connection (RS485) .....	20
5.7 Disposal .....	20
<b>6 - OPERATING PROCEDURE</b>	<b>21</b>

---

6.1	Operating principle .....	21
6.2	Display .....	22
6.3	Keys .....	22
6.4	Instruction for the user .....	23
6.4.1	Concentration measuring .....	23
6.4.2	Temperature measuring .....	23
6.4.3	Parameters reserved to the plant maintainer .....	23
6.4.4	Parameters reserved to the plant engineer .....	24
6.4.5	Information display .....	24
6.5	Maintenance instruction .....	24
6.5.1	Preliminary operations .....	24
6.5.2	Making measurements .....	24
6.5.3	Concentration calibration .....	25
6.5.4	Temperature calibration .....	27
6.5.5	Setup .....	28
6.5.6	Maintenance of the transmitter .....	28
6.5.7	Maintenance of the sensor .....	29
6.6	Installation instruction .....	29
6.6.1	Safety requirements .....	29
6.6.2	Configuration .....	30
6.7	Operating modes .....	31
6.8	Analog mode .....	31
6.9	Digital operation .....	32
6.9.1	B&C communication protocol .....	32
6.9.2	Modbus protocol .....	46
<b>7 - INSTALLATION DRAWINGS</b>		<b>55</b>
<hr/>		
7.1	Connections .....	55
7.2	Dimensions .....	56
7.3	Analog mode wiring .....	57
7.4	Digital mode wiring .....	58
<b>8 - WARRANTY</b>		<b>59</b>
<hr/>		
<b>9 - REPAIRS</b>		<b>59</b>
<hr/>		

# 1 GENERAL WARNINGS AND INFORMATION FOR ALL USERS

## 1.1 WARRANTY

This product is guaranteed for 5 years from the date of purchase for all manufacturing defects.

Please take a look at the terms and conditions described on the warranty certificate at the end of the manual.

## 1.2 AFTER SALES SERVICE

B&C Electronics offers to all of its customers the following services:

- a free of charge technical assistance over the phone and email for problems regarding installation, calibration and regular maintenance;
- a repairing service in our Carnate (Italy) headquarter for all types of damages, calibration or for a scheduled maintenance.

Please take a look at the technical support data sheet at the end of the manual for more details.

## 1.3 CE MARKING

This instrument is manufactured according to the following european community directives:

- 2011/65/EU "Restriction of the use of certain hazardous substances in electrical and electronic equipment"
- 2014/30/EU "Electromagnetic compatibility" EMC
- EN 61326-1/2013 "Electromagnetic compatibility" EMC
  - Industrial electromagnetic environment
- EN 55011/2009 "Radio-frequency disturbance characteristics"
  - Class A (devices for usage in all establishment other than domestic)
  - Group 1 (Industrial equipment that do not exceed 9kHz)

The  marking is placed on the packaging and on the S/N label of the instrument.

## 1.4 SAFETY WARNINGS

It is important to underline the fact that electronic instruments are subject to accidental failure.

For this, it is important to take all necessary precautions to avoid damages caused by malfunctions.

Any operation must be performed by authorized and trained staff.

The use of this transmitter must comply with the parameters described in chapter "Technical data (page 12)", in order to avoid potential damages and a reduction of its operating life.

## 1.5 MANUAL REVISIONS

This chapter shortly describes the differences between previously released versions of the same manual, so to help users that are already familiar with the product.

Rev. B	Firmware R3.0 Modbus RTU function 06 and 16 ID+SN commands Bootloader function Hidden negative function
Rev. A	Emission

## 2 PRODUCT OVERVIEW

### 2.1 FUNCTIONAL PURPOSE OF THE DEVICE

The system for monitoring free chlorine, combined chlorine, total chlorine, chlorine dioxide, dissolved ozone, and other oxidizers consists of two main parts:

- the transmitter described in this instruction manual;
- the probe/measuring sensor.

The instrument operates in analog and/or digital functionality.

The transmitter performs the following functions:

- display of the oxidizers values of the aqueous solutions, by using a suitable measuring sensor;
- display of the temperature values, by using a Pt100 temperature sensor;
- perform the manual or automatic temperature compensation;
- operate in analog or digital mode;
- transmit the data of the main measurement and of the temperature on the serial interface;
- connect to a master for remote configuration;
- activate the hold function of the current loop through an external free voltage contact.

### 2.2 ACCESSORIES

Sensors and accessories for different applications are available, to be ordered separately.

Our web site [www.bc-electronics.it](http://www.bc-electronics.it) contains accessories, upgrades and detailed specifications of each product.

Our staff is always available to help costumers select the most appropriate and suitable solution for their specific needs.

## 3 INSTRUCTION MANUAL CONTENTS

This chapter describes the manual and gives suggestions to all users on how to read it and use it.

The manual is written according to the following norms:

- UNI 10893 "Instructions for use";
- UNI 10653 "Quality of product technical documentation".

The terminologies indicated in the international metrology vocabulary (VIM) are respected as far as possible.

### 3.1 SYMBOLS

Throughout the manual you may find the following symbols, which are both dictated by a norm or that are simply conventional.



**WARNINGS:** this symbol is used to warn users that if the instructions are ignored or not correctly followed, damage to the instrument can be caused.



**NOTE:** *this symbol is to invite the user to pay particular attention to a specific section of the manual.*

### 3.2 HOW TO READ THE INSTRUCTION MANUAL

The manual contains all the information needed to acquire full knowledge of the product, to ensure a proper installation, proper use and maintenance in order to achieve the desired result at the time of its choice.

The manual is aimed at staff with appropriate knowledge and experience in the field of measurement and control through the use of sensors and transmitters in the context of industrial plants.

The index of the manual refers the reader to the chapters on aspects that want to learn and develop.

In particular, the first chapters show general topics and allow the user to become familiar with the product, with its functional purpose and with the necessary accessories or options for its use.

The user can then check whether he knows all the elements necessary for the use of the instrument and of the measuring/control.

The instrument has been designed keeping in mind three different types of use: generic use (end user), control (maintenance staff), installation (plant engineer).

-  *The user is normally interested on the display and will have to refer to the chapter:*
- *"Instruction for the user (page 23)".*

*The maintainer of the system, will be more interested in the chapters of the manual concerning:*

- *"Instruction for the user (page 23)";*
- *"Maintenance instruction (page 24)";*
- *"Warranty (page 59)";*
- *"Repairs (page 59)".*

*The plant engineer will have to make a complete reading of the chapters and consulting explanatory drawings in order to:*

- *verify that the technical and functional characteristics are conformed with the plants requirements;*
- *verify that the environmental and climatic conditions required by the instruments are respected;*
- *make the correct electronic connections;*
- *become familiar with the instrument's firmware;*
- *configure the instrument according to the application;*
- *run all of the necessary tests before starting the instrument;*
- *calibrate the instrument once the sensor is connected.*

-  *The data shown in the displays in this manual are only illustrative.*

### 3.2.1 USING THE INSTRUMENT ON THE PLANT

For the generic use, the end user can operate with a locked keyboard (suggested mode and to be set by maintenance staff). By this, he can check the set point parameters without the possibility of changing the configured set points values and the zero/sensitivity calibration.

### 3.2.2 PLANT MAINTENANCE STAFF

Maintenance staff can select the operating values, by setting the desired parameters of the setup menu and after inserting the password. He can also enable the user's access to calibration, set point and alarm settings.

The location of this set parameters can be seen in the left column of the technical specifications table and they are identified by a letter "S" followed by a number.

The operations that need to be done during the start-up and the periodical tests are the following:

- to allow only the visualization of the measures during the normal use;
- to calibrate the sensors by means of ZERO and SENS keys;
- to set the following parameters:
  - response time of the filter software;
  - temperature measuring unit in °C or °F;

- manual temperature compensation;
- reference temperature for the temperature compensation;
- temperature coefficient;
- to modify the password to access the setup.

### 3.2.3 INSTRUMENT INSTALLATION

The plant engineer, by inserting the access password and by setting and modifying the configuration parameters, will be able to select the necessary functions required by the plant.

The location of this set parameters can be seen in the left column of the technical specifications table and they are identified by a letter "C" followed by a number.

The operations that need to be done during the instrument installation are the following:

- LO/HI current of the cell;
- polarization voltage;
- ppm or mg/l measuring unit;
- input scales 2.000 - 20.00 - 200.0;
- current loop enable/disable;
- scale factor 10/100 %;
- baud rate of the RS485 interface;
- B&C or Modbus protocol ID;
- password to access the configuration.

## 4 SPECIFICATIONS AND TECHNICAL DATA

### 4.1 FUNCTIONAL SPECIFICATION

#### Display

The instrument is equipped with an alphanumeric LCD display 8x1 characters.

The display shows the measured values and messages which guide the operator in the use of the instrument.

The messages are alternating displayed.

#### Keyboard

The instrument has a 4 keys keyboard, which perform a dual function when pressed for more than 3 seconds allowing the access to all functions available. The combined pressure of a few buttons allows to perform additional functions described in specific points of the manual.

#### Inputs

The instrument is able to perform the measurement of the oxidizers by using 2 or 3 electrodes specific sensors, by selecting the current value (HI/LO) provided by the cell.

The temperature in °C or °F is measured by a 3-wire RTD Pt100.

#### Scales

The instrument allows the selection of three measuring scales in each current range obtained from the sensor.

The measuring unit is selectable in ppm or mg/l. See table in section "Technical data (page 12)".

With a selectable scale factor of 10% and 100% in configuration, it is possible to obtain intermediate scale values on the current loop.

Negative reading values can be suppressed if necessary.

#### Temperature compensation

The instrument displays the temperature value in the field  $-10.0 \div 100.0$  °C or  $14.0 \div 230.0$  °F and it performs the manual or automatic temperature compensation.

For absence or malfunction of the temperature sensor it automatically switches to manual compensation, by displaying the value of the compensation temperature.

The reference temperature is 20 °C.

The temperature coefficient can be set in function of the specific applications.

#### Calibration

The instruments allows to perform the zero and sensitivity calibration in a wide range, in order to extend the useful life of the sensor.

## Analog output

The instrument operates in the current loop 4-20 mA proportional to the value of the principal measure.

The output is galvanically isolated, therefore directly interfaceable to a PLC, data acquisition cards or B&C Electronics instruments with 4/20 mA input.

## Serial interface

Through the isolated RS485 interface, the user can connect the transmitter to a terminal or to a PC using a simple terminal emulation program. A RS485/RS232 or RS485/USB converter can be necessary.

Using B&C protocol, is possible measurements receiving, parameters setting and to calibration management.

Using Modbus protocol, functions 03, 06 and 16 are implemented for reading the measurements, changing the operating parameters and calibrating.

The MC 6587 and MC 7687 controllers from B&C Electronics allow complete management of the transmitter.

The bootloader function allows the firmware's update via serial port.

## Software filter

A software filter with two selectable time constants operates on the input signal of the measuring cell.

The user can set the response time relative to the small or large variation signals separately, in order to obtain good reading stability and response speed to the variations of the measurement in the process.

## Logic input

The instrument is equipped with a logic input which connects a free voltage contact from an external device.

The function of this input is to maintain in hold the current loop.

The state of the logic input is visible in the record digital broadcast.

## Power supply

The instrument is powered (min. 9 Vdc ÷ max. 36 Vdc) through the current loop, directly from a PLC or data acquisition boards that provide the power, or by a power supply in series between the analog output and the apparatus of acquisition.

When operating in digital mode the instrument will be equally fed to the terminals of the current loop minimizing power consumption.

## Setup

The instrument is provided with a setup menu protected by a specific password where you can:

- disable the calibration functions;
- choose the response time for the small/large software filter;
- select the unit of measurement of the temperature in °C or °F;
- select the manual temperature compensation value;

- select the parameters of the temperature compensation;
- change the access password.

In case the wrong password is entered, a message will appear and you can view the parameters but not modify them.

## Configuration

The instrument is provided with a configuration menu protected by a specific password where you can select:

- the HI/LO input current;
- the polarization voltage;
- the measuring unit;
- the measuring scale;
- the current loop enable;
- the scalability factor;
- the baud rate of the RS485 interface;
- the ID for communication protocols Modbus or B&C;
- a new value of the access password.

In case the wrong password is entered, a message will appear and you can view the parameters but not modify them.

## Information menu

The instrument is provided with an information menu to show:

- p/n and firmware release;
- last calibration date;
- total operating hours.

## 4.2 TECHNICAL DATA

### 4.2.1 GENERAL SPECIFICATIONS

Room temperature	0 °C ÷ +50 °C
Relative humidity	up to 95 % without condensation
Protection of transmitter	IP40
Weight	250 g
Dimensions	71 x 95 x 58 mm
Mounting	Rail din 4 modules
Display	LCD COG 8x1 characters
Characters dimensions	11.97 x 4.97 mm
Long messages	sent alternately (title + variable)
Connections	removable terminal blocks 3.5 mm pitch
Isolation in/out	500 Vdc
Immunity performance loss	< 1 % full scale
EMC/RFI conformity	EN61326
Registered design	002564666-001

## 4.2.2 TECHNICAL SPECIFICATIONS

In the left column indicates the number of the display concerned:

- SETUP parameters are indicated by "S xy"
- CONFIGURATION parameters are indicated with "C xy" where  
x = paragraph y = sequential 1..2..3..4..ecc

D1.0	MEAN MEASURE			Default
	Sensor type	2 wires / 3 wires		
C1.1	Sensor current	LO / HI (LO=160 nA/ppm, HI=2000 nA/ppm)		HI
C1.2	Polarization	-1000 ÷ 1000 mV		-200 mV
C1.3	Measuring unit	ppm / mg/l		ppm
C1.4	Scales	2.000 ppm / mg/l 20.00 ppm / mg/l 200.0 ppm / mg/l		20.00
	Scales	Resolution	Measure limits	Reading limits
	2.000 ppm/mg/l	0.001	-0.100 / 2.100	-0.200 / 2.200
	20.00 ppm/mg/l	0.01	-1.00 / 21.00	-2.00 / 22.00
	200.0 ppm/mg/l	0.1	-10.0 / 210.0	-20.0 / 220.0
C1.5	Hidden negative	ON / OFF		OFF
S1.2	RT 90 % large signal	1 ÷ 20 seconds		2 s
S1.3	RT 90 % small signal	1 ÷ 20 seconds		10 s
	Measure update	0.5 seconds		
D1.1	Zero	±2000 nA (HI current) ±200 nA (LO current)		0 nA
	Calibration	MANUAL correction on the selected scale and sensor's current offset		
D1.2	Sensor sensitivity	12.5 ÷ 250 %		100 %

<b>D2.0 SECONDARY MEASURE</b>			<b>Default</b>
D2.0	Measure	Temperature	
	Input	RTD Pt100 3 wires	
S2.1	Measuring unit	°C / °F	°C
	Temperature compensation	manual without RTD automatic with RTD	
	Scales	-10.0 ÷ 110.0 °C 14.0 ÷ 230.0 °F	
	Resolution	0.1 °C / °F	
	Zero	± 5.0 °C ± 9.0 °F	0.0 °C 0.0 °F
S2.2	Manual temperature	0.0 ÷ 100.0 °C 32.0 ÷ 212.0 °F	20.0 °C 68.0 °F
	Reference temperature	20 °C	20 °C
S2.3	Temperature coefficient	0.00 ÷ 4.00 %/°C	2.00 %/°C

<b>CURRENT LOOP</b>			<b>Default</b>
C5.1	Current loop	enabled / disabled	enabled
	Current loop proportional to the measure	4-20 mA	
C5.2	Scalability factor	10 ÷ 100 %	100 %
	Under range	3.80 mA	
	Over range	20.80 mA	
	ID of the selected scale (current loop enabled)		
	• Scale 2.000	11 mA at switching on for 8"	
	• Scale 20.00	12 mA at switching on for 8"	
	• Scale 200.0	13 mA at switching on for 8"	

<b>DIGITAL OPERATION</b>		<b>Default</b>
Protocols	B&C protocol ASCII / Modbus RTU The two protocols can coexist	

<b>DIGITAL OPERATION</b>			Default
C8.2	B&C ID protocol	ID=01 ÷ 99 last s/n digit, if 0 ID=10	01 ÷ 10*
C8.3	Modbus address	ID=01 ÷ 243 last s/n digit, if 0 ID=10	01 ÷ 10*
Measures and parameters are provided under interrogation (see protocols B&C ASCII and Modbus RTU function 03 - 06 -16)			
	Interface	RS485 isolated not terminated	
C8.1	Baud rate	2400 / 4800 / 9600 / 19200 baud	9600 baud
	Distance of connection	1000 / 500 / 250 / 125 m	
	Use in network	32 transmitters max	

<b>DIGITAL INPUT</b>		Default
	Digital input	Free voltage contacts in closure
	Digital function	Hold of the loop 4-20 mA (The input state is visible on the digital protocols)

<b>D50.0</b>	<b>SETUP</b>		Default
50.1	Password to access the setup	000 ÷ 999	000
S1.1	Calibration inhibition	On / Off	Off
S1.2	RT 90 % large signal	1 ÷ 20 seconds	2 s
S1.3	RT 90 % small signal	1 ÷ 20 seconds	10 s
S2.1	Temperature measuring unit	°C / °F	°C
S2.2	Manual temperature	0 ÷ 100 °C 32 ÷ 212 °F	20 °C
S2.3	Temperature coefficient	0.00 ÷ 4.00 %/°C	2.00 %/°C
S50.0	Password changing	000 ÷ 999	000

<b>D60.0</b>	<b>CONFIGURATION</b>		Default
60.1	Password to access the configuration	000 ÷ 999	000
C1.1	Sensor current	LO / HI	HI
C1.2	Polarization	-1000 ÷ 1000 mV	-220 mV
C1.3	Measuring unit	ppm / mg/l	ppm
C1.4	Measuring scales	2.000 / 20.00 / 200.0	20.00
C1.5	Hidden negative	ON / OFF	OFF
C5.1	Current loop	enabled / disabled	enabled

<b>D60.0 CONFIGURATION</b>			<b>Default</b>
C5.2	Scalability factor	10 ÷ 100 %	100 %
C8.1	Baud rate	2400 / 4800 / 9600 / 19200 baud	9600 baud
C8.2	B&C ID protocol	ID=01 ÷ 99 last s/n digit, if 0 ID=10	01 ÷ 10
C8.3	Modbus address	ID=01 ÷ 243 last s/n digit, if 0 ID=10	01 ÷ 10
C60.0	Password changing	000 ÷ 999	000

<b>D70.0 INFO MENU</b>			<b>Default</b>
I1.0	P/N and firmware release	CL3436 Rev3.xx	
I2.0	Scale / Last calibration date	Scale / XX/XX/XX	00/00/00
I3.0	Total hours of operation	XXXXXX h	

<b>POWER SUPPLY</b>			<b>Default</b>
	Voltage	min 9 Vdc / max 36 Vdc	
	Current - current loop disabled	< 4 mA a 9 Vdc (in absence of communication)	
	Current - current look enabled	4-20 mA, 21 mA max	
	The current can be higher during the communication		

## 5 INSTALLATION

### 5.1 PACKING LIST

The package contains:

- N° 1 unit with serial number label;
- N° 1 instruction manual.

### 5.2 PACKING AND UNPACKING

- 1 Open the carton box and keep it.
- 2 Remove the instrument for the carton box.
- 3 Remove the plastic protection from the instrument.

If repackaging do the reverse.

### 5.3 STORAGE AND TRANSPORT

For prolonged storage, keep the product in dry places.

In case of transportation, pack the product in a carton box.

### 5.4 INSTALLATION OF THE TRANSMITTER

The instrument can be installed in a watertight box or in an electrical control panel with a DIN rail.

### 5.5 INSTALLATION OF THE SENSOR

Follow the specific instructions of the flow-through or immersion sensors for the installation.

The measures of oxidizing agents in water can depend on the sample stream. For this reason, they are placed in special overflow cell to keep the flow constant.

In case of in-line installation the sample flow should be maintained constant.

The sensors whose measurement is not dependent on flow can also be installed in immersion.

Protect the cable of the sensor from rain or corrosive agents, for example using a sheath.

Interruptions on the sensor cable may cause interference.

When necessary (for example for cable extension) use high insulation terminal blocks protected from moisture (for example, the derivation accessory SZ 740).

Keep the cable of the sensor away from the power cables.

## 5.6 ELECTRICAL INSTALLATION

For all electrical connections, refer to the label on the instruments, also shown and described in chapter "Installation drawings (page 55)".

All the connections to the instrument are made using removable terminal blocks.



Electronic instruments are subject to accidental failure.

Predict the necessary precautions to avoid any damage caused by their malfunction.

### 5.6.1 CONNECTION OF THE MEASURING CELL

#### Two electrodes sensors

- Connect the cathode to the terminal 12 marked IN-.
- Connect the anode to the terminal 9 marked CE.
- Install a jumper between 9-10 terminals marked CE and R.

#### Three electrodes sensors

- Connect the cathode to the terminal 12 marked IN-.
- Connect the anode to the terminal 9 marked CE.
- Connect the third electrode (reference) to the terminal 10 marked R.

Connection of the most popular sensors:

#### Connection of the 2-electrodes polarographic cell (CL7901 - CL7902 - OZ7901)

The measuring cell includes a Pt100 temperature sensor and is provided with cable whose wires are identified by their color.

- Connect the brown or orange wire (cathode) to the terminal 12 marked IN-.
- Connect the white wire (anode) to the terminal 9 marked CE.
- Install a jumper between terminals 9-10.
- Connect the red wire (Pt100) to the terminal 13 marked T1.
- Connect the black wire (Pt100 common) to the terminal 14 marked T2.
- Connect the green wire (Pt100 common) to the terminal 15 marked T0.

#### Connection of the potentiostatic sensor

The SZ 283 potentiostatic sensor is provided with a shielded cable with two wires identified by their color.

- Connect the black wire (cathode) to the terminal 12 marked IN-.
- Connect the white wire (counter electrode) to the terminal 9 marked CE.
- Connect the shield (reference) to the terminal 10 marked R.

 The connection of the sensors is the most critical part of the whole system.

Application of voltages not related to the process can damage the circuitry of the input amplifier:

- use only the cables supplied with the sensor;
- avoid interruptions in the cables. If necessary use only special terminal blocks at a very high insulation and protection from moisture;
- keep the cell cable far from the power cables inside the electrical panel.

## 5.6.2 CONNECTION OF THE TEMPERATURE SENSOR

To display the temperature value and for the automatic compensation of the effect of temperature on the conductivity measurement is necessary to connect the temperature sensor Pt100 RTD as shown in chapter "Installation drawings (page 55)", using the appropriate wire section.

If the temperature sensor is not connected, or is interrupted or in short circuit, the instrument automatically switches to the manual temperature compensation.

### Two-wire Pt100 connection for short distances

- Connect the Pt100 to terminals 13-14 (marked T1 e T2) and short terminals 14-15 (marked T2 e T0).

### Three wire Pt100 connection for great distances

- Connect a Pt100 wire to the terminal 13 marked T1.
- Connect one common wire of the Pt100 to terminal 14 (marked T2) and the other common wire to terminal 15 (marked T0) using two separate wires.

 Do not interrupt the connection cable.  
Use extension cable through high isolation junction box;  
Keep the cable away from the power cables.

## 5.6.3 CONNECTION OF THE CURRENT LOOP

The instrument provides an output current proportional to the primary measure to drive an external recorder, PLC or other similar devices.

- Connect the (+) terminal of the power supply to the terminal 3 marked ±.
- Connect the return of the loop (-) to the terminal 2 marked -.

If the analog signal must drive more devices, they must be connected in "series" with each other, respecting the maximum value of resistance as a function of the supply voltage.

## 5.6.4 CONNECTION OF THE LOGIC INPUT

The free voltage contacts in closure from an external device must be applied to the logic input terminals 7 and 8 marked GND and DI.

 Do not give any power to the logic input terminals.

### 5.6.5 CONNECTION TO THE RS485 SERIAL PORT

The instrument can be configured as a slave device and communicate via the serial port. There are two types of protocol as described in chapter "Digital operation (page 32)".

- Connect the positive differential of the RS485 interface to terminal 5 marked A+.
- Connect the negative differential of the RS485 interface to terminal 6 marked B-.
- Connect the eventual ground of the RS485 interface to terminal 7 marked GND.

### 5.6.6 NETWORK CONNECTION (RS485)

These digital transmitters use a RS485 driver with slow switching fronts.

This implies that it is not necessary to complete the termination of the transmission line even for long distances.

The following directions are to be considered as examples.

If the driver of the master device has very fast switching fronts, it may be necessary to terminate the beginning and end of the transmission line.

In this case it should be inserted in the transmission line an AC termination by inserting a capacitor in series with the terminating resistor at the beginning and end of the transmission line.

The purely resistive termination is not tolerated by the transmitter as the internal power supply does not support high loads.

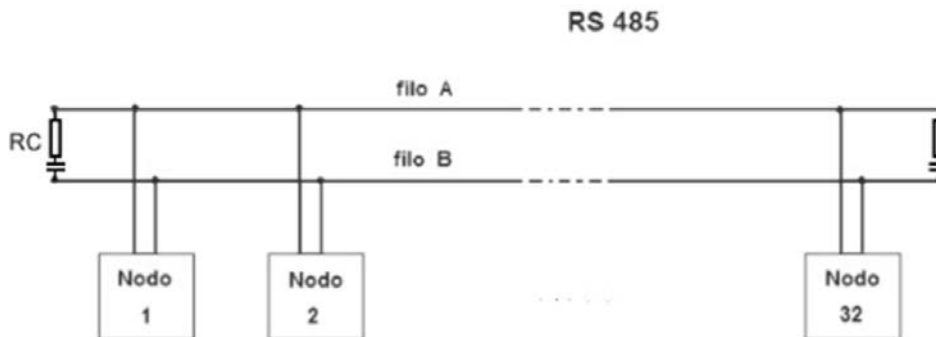

By way of example, the value of the capacitor will have the following values depending on the length of the line: 10 nF (150 m) - 22nF (300 m) - 47 nF (600 m) - 100 nF (1000 m).

## 5.7 DISPOSAL

In case of disposal of the instrument, apply the terms of the law provided for the disposal of electronic devices.

## 6 OPERATING PROCEDURE

### 6.1 OPERATING PRINCIPLE

This instrument measures the oxidizing substances in water with two types of sensors:

- two or three electrodes immersed in an electrolyte separated from the sample by a membrane selective to the substances to be measured;
- three-electrode amperometric cell, commonly called "potentiostatic sensor".

In the two electrodes cell is applied a suitable polarization voltage to the two metal electrodes (anode and cathode) through which flows the electric current proportional to the concentration of the oxidizers present in the solution.

In the three electrodes cell is applied a suitable bias voltage to the two metal electrodes (anode and the counter electrode) in contact with the sample, through which flows the electric current proportional to the concentration of the oxidizers present in the solution.

A reference electrode is used to compensate the internal electrical resistance and the oxidation-reduction potential that occur on the measuring.

The main advantages of the potentiostatic measuring technique are the following:

- a steady and accurate relationship between cell current and concentration of the dissolved oxidizers, especially to very low values;
- the measured value in water without the presence of oxidizers is practically equal to zero;
- the frequency of the instrument calibration in the field is considerably reduced.

In both types of sensor the flow of current makes a chemical reaction in proximity of the electrodes. For this reason the oxidizer must be renewed by means of a constant flow of the sample so to maintain a correct value of the measure.

The constant flow of the sample is obtained by means of a special overflow cell whose use is recommended.

In both cases, you can make corrections (zero and sensitivity) to compensate for changes in sensor response due to the conditions of use and pH values, in some cases.



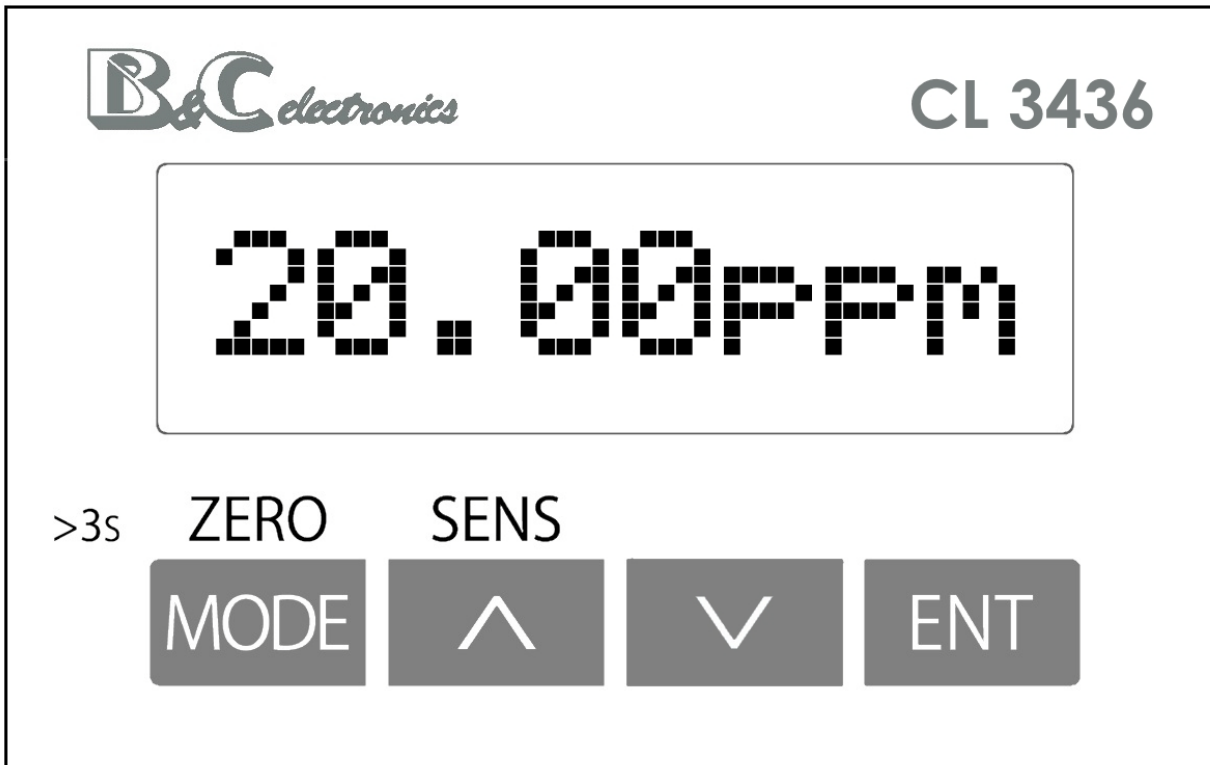

The temperature influences the activity of the ionic solution and with it the signal provided by the sensor. For this reason in applications where the temperature of the liquid is significantly different from the reference value of 20 °C, it is suggested to use the temperature compensation.

The user needs to evaluate the installation of a Pt100 in order to perform the automatic compensation in case of significant temperature fluctuations.

## 6.2 DISPLAY



## 6.3 KEYS

KEY	FUNCTION
<p>ZERO</p> 	<p>Key MODE/ZERO</p> <ul style="list-style-type: none"> <li>- Visualize the sequence of the functions</li> <li>- Exit without changing the visualized value</li> <li>- &gt;3s Start the zero calibration</li> </ul>
<p>SENS</p> 	<p>Key UP/SENS</p> <ul style="list-style-type: none"> <li>- Increase the value</li> <li>- Access to the parameter changing</li> <li>- &gt;3s Start the sensitivity calibration</li> </ul>
	<p>Key DOWN</p> <ul style="list-style-type: none"> <li>- Decrease the value</li> <li>- Access to the parameter changing</li> </ul>
	<p>Key ENTER</p> <ul style="list-style-type: none"> <li>- Confirm the visualized value</li> <li>- Go to the next parameter (in setup and configuration)</li> <li>- Access to the secondary menu and parameters</li> <li>- &gt;3s Activate and deactivate the hold function</li> </ul>

## 6.4 INSTRUCTION FOR THE USER

### 6.4.1 CONCENTRATION MEASURING

The display shows the concentration values as selected in the configuration menu.



The image shows a rectangular LCD display with a black border. Inside, the text "20.00PPM" is displayed in a pixelated, monospaced font. The "20" is on the top line, ".00" is on the second line, and "PPM" is on the third line.

If the values are below/above the limits of reading will be shown respectively the messages <<<< and >>>> followed by measuring unit.

Approaching the limits of measurement will be displayed alternately the reading and the value of the output current.

From main measurement display 1.0 the user can access the calibration procedures, if they have not been reserved to the maintainer.

ENT to visualize the output current value.

### 6.4.2 TEMPERATURE MEASURING

The display shows the value of the temperature measurement (real or set), the measuring unit (\*C or \*F) and M in case of absence of the temperature probe.



The image shows a rectangular LCD display with a black border. Inside, the text "20.0°C" is displayed in a pixelated, monospaced font. The "20" is on the top line, ".0" is on the second line, and "°C" is on the third line.

From this display the user can access the calibration procedure of the temperature probe, if this has not been reserved to the maintainer.

### 6.4.3 PARAMETERS RESERVED TO THE PLANT MAINTAINER

From this display the user can access the maintenance menu of the instrument (setup) via password.

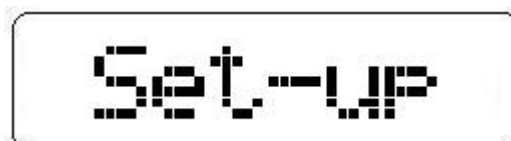

The image shows a rectangular LCD display with a black border. Inside, the text "Set-up" is displayed in a pixelated, monospaced font. "Set" is on the top line and "-up" is on the second line.

#### 6.4.4 PARAMETERS RESERVED TO THE PLANT ENGINEER

From this display the user can access the installation menu of the instrument (configuration) via password.



Confia.

#### 6.4.5 INFORMATION DISPLAY

From this display the user can access the information of the instrument.



Info

ENT - to access to the functioning informations  
- to set/visualize the last calibration date  
- to visualize the total hours of operation

MODE to access to the main measurement display.

### 6.5 MAINTENANCE INSTRUCTION

#### 6.5.1 PRELIMINARY OPERATIONS

Any checking operation must be done with the measuring cell connected to the input of the device.

In particular, check that the instrument has been properly configured for the type of use.

To verify the parameters without modifying them follow the operating procedures described in paragraph "Setup (page 28)".

The display provides all the information necessary for the preliminary checks of operation.

The lighting of the display indicates that the unit has power and power circuits are working properly.

#### 6.5.2 MAKING MEASUREMENTS

To operate the system installed, verify the connection of the following components:

- the measuring cell and the eventual RTD in contact with the liquid under test;
- the logic input if necessary.

Provide the power to the current loop and read the oxidant's concentration value of the liquid under test.

If the sensors are connected properly, as described in chapter "Installation (page 17)", the system will operate on a regular basis and require only the calibration.

### 6.5.3 CONCENTRATION CALIBRATION

Install the measuring cell and connect it to the instrument.

On the main measurement can be performed the zero calibration and the sensor's sensitivity calibration.

All the calibration operations must be done after a proper time to permit the polarization of the sensor as described on the sensor's instruction manual.

 *The newly installed chlorine sensors require a few hours of operation before providing a proper measure.*

*During the initial phase of operation the instrument will provide a higher reading than the actual one.*

*It is recommended to keep the sensor polarized in water without chlorine for a few hours before proceeding with the calibration which in any case must be refined after a few days of work.*

If the reservoir of the membrane sensor is empty, it must be filled with the electrolyte provided with the sensor.

Refer to the sensor instructions.

The calibration of the meter in case of temperature compensation requires special precautions:

- set the manual temperature value in the setup menu;
- set the correct value of temperature coefficient in the set up menu;
- install the temperature sensor in case of automatic compensation;
- wait until the sensor has reached a state of thermal equilibrium with the solution itself. This state of equilibrium can be considered achieved when the display marks stable values.

#### Zero calibration

If necessary the zero calibration is done as follows:

- send a sample to the measuring cell without chlorine or/and other oxidants content and observe the progressive approximation of the extent to values close to zero;
- when the reading is stable you can proceed with the zero calibration procedure described below.

 *Membrane polarographic sensors, never installed or following the replacement of the membrane and/or the electrolyte, can employ long times to reach the stabilization to a minimum value because the electrodes immersed in the electrolyte of the sensor should complete the polarization process.*

 *The potentiostatic sensors are faster in response and the zero calibration can be performed with the dry sensor in air.*

- MODE (ZERO) by pressing this button for more than 3 seconds, the message **Zero Cal** appears alternately to the actual value or **Cal lock** if the calibration was inhibited in the setup (Display S1.1).
- UP/DOWN to modify the value.
- ENT to confirm the new value.

If the zero value is outside the acceptable limits described in the technical specifications, the display will show the error message **Zero err**.

The message **Update** indicates that the calibration has been stored.

- ENT to delete the message and return to the main display.

If the new value is accepted, the display will show for a few seconds the message **Last cal** and propose the recording of the calibration date.

-  *The reset to zero factory in the main display is done as follows: start the calibration of zero, simultaneously press the UP, DOWN and ENT; the messages **RES Zero** and **Last cal** will appear for a few seconds.*
- Proceed with the insertion or modification of date as in the previous case.*

## Sensitivity calibration

The calibration of the sensor sensitivity can be made only knowing the real value of sample concentration.

Normally the sample concentration is previously measured with a field photometric instrument suitable for the measurement of the sample.

You must select the photometer able to perform the measurement of the sample at the desired scale and with adequate precision.

It's also important to perform sensitivity calibration at higher values possible in order to obtain a good precision of the measurement on all the chosen scale.

If this is not possible, it is suggested to perform the zero calibration (one point calibration).

- UP (SENS) by pressing this button for more than 3 seconds, the message **Sens Cal** will appear alternately to the actual value or **Cal lock** if the calibration was inhibited in the setup (Display S1.1). Wait for the stabilization of the value.
- UP/DOWN to modify the value.
- ENT to confirm the new value.
- MODE to return to the main display without modifying the value.

If the new value exceeds the limits of acceptability shown in the technical specifications of the instrument, the error **Sens err** will appear.

The message **Update** indicates that the calibration has been stored.

ENT to delete the message and return to the main display.

If the new value is accepted, the display will show for a few seconds the message **Last. cal** and propose recording the date of calibration.

 *The reset to sensitivity factory in the main display is done as follows:*

*start the calibration of sensitivity, simultaneously press the UP, DOWN and ENT; the messages **RES Sens** and **Last. cal** will appear for a few seconds.*

*Proceed with the insertion or modification of date as in the previous case.*

## One point calibration

In some cases it may be considered enough to calibrate only one point. In this case, it is suggested to calibrate the zero if the application measure is close to zero, as opposite you may calibrate sensitivity if the values are not less than 10% of full scale.

## Error message

The two error messages provided by the instrument during calibration operations indicate that the sensor is in an unacceptable operating condition (and therefore risky for the system).

In fact, the instrument controls zero deviations higher than  $\pm 2000$  mA /  $\pm 200$  mA and sensitivity deviations less than 12.5 % or more than 250 % of the full scale.

In case of these errors, it is suggested to check the sensor, replace the membrane or install a new sensor.

## 6.5.4 TEMPERATURE CALIBRATION

It can be made when the Pt100 sensor is connected.

Immerse the Pt100 in a liquid or keep the sensor in the air knowing the value of the temperature.

MODE press the key from the main display to go to D2.0 display.

MODE (ZERO) press the key for more than 3 seconds.

The message **Zero cal** will appear alternately with the temperature value.

Wait for the stabilization of the temperature value on the display.

UP/DOWN to modify the values.

The display will show the actual value **XXX.X °C o °F**.

UP/DOWN to modify the value.

ENT to confirm the entered value.

MODE to return to the main display without modify the values.

The message **Update** indicates the calibration is stored.

If the new value exceeds the limits shown in the specification, the message **Zero err** will appear.

 *The reset to factory value in the main display is done as follows: start the calibration of temperature, simultaneously press the UP, DOWN and ENT; the message **RES Zero** will appear for a few seconds.*

### 6.5.5 SETUP

- MODE            press the key two times from 1.0 display to get the message Set-up (display 50.0).
- ENT             to scroll through the setup functions.
- UP/DOWN       to change the value or the option visualized on the display.
- ENT             to confirm the changings; the message Update will appear.
- MODE           to exit form the procedure and to turn to the 50.0 display.

Display	Content	Meaning	Possible values
50.1	PASS 000	Password to access the setup menu	000 ÷ 999
S1.1	Cal lock	Inhibition of the zero and sensitivity calibration	On Off
S1.2	RT large	Response time of the large filter software	1 ÷ 20 s
S1.3	RT small	Response time of the small filter software	1 ÷ 20 s
S2.1	T Unit	Measuring unit of the temperature	°C °F
S2.2	T man	Manual temperature values	0.0 ÷ 100.0 °C 32.0 ÷ 212.0 °F
S2.3	Temp. Co	Temperature coefficient	0.00 ÷ 4.00 %/ °C
S50.0	Set-up	Password setting	000 ÷ 999

 *If the password is incorrect, the message "**WRONG PW**" will appear for 2 seconds and you can view the parameters but not modify them.*

### 6.5.6 MAINTENANCE OF THE TRANSMITTER

The use of electronic components of high quality gives the instrument characteristics of great reliability.

The frequency of any maintenance depends on the particular use of the instrument.

-  Disconnect the power supply to the unit before performing the following procedures:
- dust removal from the terminal;
  - operations on the wires connecting the terminal;
  - mounting of the instrument in the switch board.

As with any electronic device mechanical components such as buttons and terminal blocks are the most prone to failure.

- Periodically check that the device is not subject to excessive moisture.
- Check that the connections to the terminal are free of dust and corrosion.
- Check that the terminal screws are tight.

## 6.5.7 MAINTENANCE OF THE SENSOR

It is recommended to perform periodical maintenance of the sensor as described below, so to avoid incorrect measurements.

The sensor must be inspected and cleaned regularly, most frequently in the case of applications in alkaline liquids or fat-containing or organic substances.

Periodically, according to the needs of the application, it is suggested to perform the calibration operations.

In case of no use for long periods, store the potentiostatic sensor with the protective cap containing a storage liquid, or tap water.

Do not use distilled water.

 *For membrane sensors storage, refer to the sensor's instruction manual.*

## 6.6 INSTALLATION INSTRUCTION

### 6.6.1 SAFETY REQUIREMENTS

 After performing the installation (chapter "Installation (page 17)"), before switching on and configuring the instrument do the following operations:

- check that all connections are correct;
- check that all connections are fastened on the terminal;
- check that the mechanical attachment of the cables does not cause any twisting or bending on the terminal blocks.

 The damage due to incorrect connections during installation are not covered by warranty.

## 6.6.2 CONFIGURATION

MODE	press the key three times from 1.0 display to get the message Config. (display 60.0).
ENT	to scroll through the configuration parameters.
UP/DOWN	to change the value or the option visualized on the display.
ENT	to confirm the changings; the message Update will appear.
MODE	to exit form the procedure and to turn to the 60.0 display.

Depending on the configuration of the instrument configuration parameters may not be displayed.

Display	Content	Meaning	Possible values
60.1	PASS 000	Password to access the configuration menu	000 ÷ 999
C1.1	Current	Current from the sensor	LO/HI
C1.2	Polariz.	Polarization	-1000/1000 mV
C1.3	Measure	Measuring unit	ppm - mg/l
C1.4	Scale	Measuring scale	2.000 - 20.00 - 200.0
C1.5	Hide neg	Hide negative	ON / OFF
C5.1	Loop	Current loop enable/disable	enable disable
C5.2	Scalable	Scale factor	10/100 %
C8.1	BaudRate	Baud rate (bit/s) selection	2400/4800 9600/19200
C8.2	B&C ID	ID for the B&C protocol	01 ÷ 99
C8.3	ModbusID	ID for the modbus protocol	01 ÷ 243
C60.0	Config.	Password setting	000 ÷ 999

If the password is incorrect, the message "**WRONG PW**" will appear for 2 seconds and you can view the parameters but not modify them.

For the most common sensors use the following parameters:

Sensor	Current	Polarization
CL7901	LO	-200 mV
CL7902	LO	-400 mV
OZ7901	LO	-200 mV
SZ283	HI	-200 mV

## 6.7 OPERATING MODES

The transmitter can be configured to operate in analog mode (current loop 4-20 mA = enable). The digital mode is always active.

 *In order to reduce the power consumption, the user can disable the current loop and operate only in digital mode.*

## 6.8 ANALOG MODE

In analogue mode the transmitter provides a 4-20 mA output current loop isolated from the sample for direct connection to a PLC or to a data logger.

The 4-20 mA output can be set within 10 to 100 % of the measuring scale.

The transmitter can be connected to a PLC or instruments BC 7335 - BC 7635 - BC 7687 - BC 6587 B&C Electronics, which allow the visualization of the measure and have two set point on/off and an alarm window.

The transmitter is supplied with the factory configuration in analogue mode (loop = enable).

When switched on the transmitter will provide for 8 seconds a current value that allow the operator to identify the scale of measurement selected in the configuration:

- 11 mA for 2.000 ppm / mg/l scale;
- 12 mA for 20.00 ppm / mg/l scale;
- 13 mA for 200.0 ppm / mg/l scale.

Subsequently, the transmitter starts supplying the 4-20mA signal proportional to the measurement on the loop.

To carry out the measurement calibration operations without altering the 4-20mA signal used in the process (for example connected to a PLC) it is possible to activate the hold function which "freezes" the value of the loop signal.

The hold function on the 4-20mA loop can be activated/deactivated:

- by closing / opening a contact on the digital input;
- from the keypad holding ENT for 3 seconds from the main display.

The keyboard-enabled hold feature has a 30-minute timeout.

## 6.9 DIGITAL OPERATION

In digital mode the transmitter is a slave device that interacts with a master device. Through the RS485 interface the transmitter can be connected to a master device.

To connect to a PC a RS485/RS232 or RS485/USB converter (like B&C Electronics' BC 8701) can be required.

The communication takes place via the RS485 connection with the B&C protocol (ASCII) and Modbus RTU (function 03, 06, 16) protocol described in the following chapters.

The transmitter can be connected to the MC 7687 - MC 6587 B&C Electronics controllers, which provide power supply, perform remote display and adjustment functions and allow complete management of the transmitter itself.

### 6.9.1 B&C COMMUNICATION PROTOCOL

Connect the transmitter to a PC for data management and calibration, using a simple terminal emulation program (example Hyperteminal).

#### Mode of transmission

Code system	ASCII
Number of bits per character:	
- start bits	1
- data bits	8
- parity	no parity
- stop bits	1
Error check (only A command)	BCC
Speed	9600 baud (default)

#### Command format using ID (01 ÷ 99)

1 or 2 byte ID transmitter (01 ÷ 99)

1 or 2 byte of command

n byte to be inserted if required by the command

1 byte <cr> (carriage return) end command

The transmitter transmits only if the ID sent is correct or is 00.



Do not use 00 ID if more than one transmitter is connected, to avoid overlap of the communication.

#### Command format using ID + SNxxxxxx

1 or 2 byte ID transmitter (01 ÷ 99)

8 byte serial number (SNxxxxxx)

1 or 2 byte of command

n byte to be inserted if required by the command

1 byte <cr> (carriage return) end command

The transmitter transmits only if the ID + serial number sent is correct or if it is 00 + serial number.

 If the communication port is set to a different speed the transmitter will not communicate.

 All the available commands are listed in the following pages.

 The list of commands implemented in the transmitter is always available by sending the command Help.

## COMMANDS USING ID

### HELP

Command format: ID + H <cr>

Example: if ID=14 type 14H <cr> or 00H <cr>

By sending the command H displays the list of available commands with a brief description of their meaning.

-----  
HELP MENU, COMMAND LIST

B&C ELECTRONICS  
-----

CL3436 CL/O3 TRANSMITTER Rev.fw:3.00 S/N:160589

```
00H <cr> Help menu
00A <cr> Acquisition
00Lx <cr> Current loop:      0001          (0=disable 1=enable)
00Fx <cr> Sensor current:   0001          (1=LO current 2=HI current)
00Px <cr> Polarization:     -0200 mV    (-1000/1000 mV)
00Mx <cr> Measure unit:     0001          (1=ppm 2=mg/l)
00Ox <cr> Analog out 4/20mA: 0002          (1=2ppm 2=20ppm 3=200ppm)
00Xx <cr> Scalable output %: 0100          (10-100% full scale)
00RLx<cr> RT90% large signal 0002 s      (1-20s)
00RSx<cr> RT90% small signal 0010 s      (1-20s)
00Gx <cr> Hidden negative:   0000          (0=OFF 1=ON)
00Wx <cr> Temp. unit         0001          (1=°C 2=°F)
00Jx <cr> Temp. adjust       not done    0.0      (5.0°C/9.0°F max) (00JR reset)
00Nx <cr> Tman                20.0 °C    (0.0-100.0°C / 32.0-212.0°F)
00Cx <cr> TC                  2.00 %/°C  (0.00-4.00%/°C)
00Vx <cr> Zero cal value:    0.00          (0.000-200.0)
00Tx <cr> Sens cal value:    20.00         (0.000-200.0)
00Z <cr> Zero calibration:   not done    0nA      (±200/2000nA) (00ZR reset zero)
00S <cr> Sens. calibration:  not done    100.0%   (12.5-250%) (00SR reset sens)
00Dx <cr> Last cal date:     00/00/00    (XX/XX/XX XX=00-99)
00Ix <cr> ID B&C:            0009          (01-99)
00Ex <cr> ID modbus:         0009          (01-243)
00Bx <cr> Baud rate:         0003          (1=2400 2=4800 3=9600 4=19200)
```

Type ID number or 00 before command. Example, if ID=15 type 15A or 00A <cr>  
Use 00A <cr> if only one probe is connected  
Query commands: 00H?,00Z?,00S?,00J?

## PARAMETERS QUERY

Command format: ID + H? <cr>

Example: if ID=14 type 14H? <cr> or 00H? <cr>

By sending the command H? displays a record containing the code and the identifier followed by all parameters including the results of calibrations.

The record transmitted uses the "," as separator.

Record format:

```
CL3436- 02,FW:3.00,SN:123456,L:0001,F:0001,P:-0200,M:0001,O:0002,X:010
.....+.....|.....+.....|.....+.....|.....+.....|.....+.....|.....+.....|.....+.....|
0,RL:0040,RS:0120,G:0000,W:0001,J:not done ± 0.0°C ,N: 20.0 °C ,C:
.....+.....|.....+.....|.....+.....|.....+.....|.....+.....|.....+.....|.....+.....|
2.00,V:0.000,T:200.0,Z:not done 0nA ,S:not done 100.0% ,D:
.....+.....|.....+.....|.....+.....|.....+.....|.....+.....|.....+.....|.....+.....|
,IA:0002,EA:0002,BA:0003,BCC:4BB8,xx
.....+.....|.....+.....|.....+.....|.....+.....|.....+.....|.....+.....|.....+.....|
```

CL3436	Transmitter code
02	Transmitter identification number

Below are transmitted parameter values measured by the transmitter with the format NAME PARAMETER: VALUE.

FW:3.00	Firmware version
SN:123456	Transmitter serial number
L:0001	Current loop enable
F:0001	Sensor current
P:-0200	Polarization
M:0001	Measuring unit
O:0001	Analog output/scale setting
X:0100	Scalable output
RL:0002	Large software filter value
RS:0010	Small software filter value
G:0000	Hidden negative
W:0001	Temperature measuring unit
J:not done 0.0°C	Temperature calibration outcome
N:20.0 °C	Manual temperature
C:2.00 %/°C	Temperature coefficient
V:0.000	Zero calibration solution value
T:200.0	Sensitivity calibration solution value
Z:not done 0nA	Zero calibration outcome
S:not done 100.0%	Sensitivity calibration outcome

D:00/00/00	Last calibration date
IA:0009	ID B&C protocol
EA:0009	ID Modbus protocol
BA:0003	Baud rate
BCC:4BB8	BCC EEPROM check
xx	2 byte BCC of transmitted record

The record transmission is ended by <cr> <lf>.

#### EEPROM BCC check use

The EEPROM BCC check is a summary of the transmitter configuration state, the value of the BCC, once set the parameters and carried out the calibration, remains constant until the next change of parameters or calibration. A variation of the BCC value without any change occurred means that an alteration has taken place in transmitter's configuration data.

#### BCC calculation

The BCC messages sent by the transmitter is calculated as the XOR of all the bytes making up the message (excluding <cr> and <lf>) and divided into 2 nibble.

The two nibbles are then transformed into their ASCII codes.

The BCC transmitted at the end of record is used to check the validity of records received.

### ACQUISITION

Command format: ID + A <cr>

Example: if ID=14 type 14A <cr> or 00A <cr>

By sending the command A, the transmitter responds by sending a record containing the code, the ID, date, time, and the value of all the measures.

#### Record format

```
CL3436- 10 0.0 01/01/01 00:00:00 ± 20.00ppm ± 20.0°C ± 2.00%/°C ±  
.....+.....|.....+.....|.....+.....|.....+.....|.....+.....|.....+.....|.....+.....|  
Ostat 18/11/10xx
```

CL3436	p/n of the transmitter
10	ID
0.0	Power voltage (not implemented)
01/01/01	Date (not implemented)
00:00:00	Hour (not implemented)

Below are transmitted the parameter values measured by the unit with the following format:

Measuring	- Sign of measure (if positive is sent a blank) - Value of measure (6 characters - right alignment)
Measuring unit	- 4 characters - left alignment - 1 blank (ASCII 32)
± 20.00 ppm	Measured value
± 20.0 °C	Temperature
± 2.20 %/°C	Temperature coefficient
± 0stat	State - bit 0 logic input: 0 = open; 1 = close - bit 1 hold from keyboard: 0 = no hold; 1 = hold - bit 2 manual temperature: 0 = auto; 1 = manual

At the end of the record the transmitter sends the last calibration date, then 2 bytes containing the BCC of the string sent.

18/11/10	Date of the last calibration
xx	2 byte BCC

The record transmission is ended by <cr> <lf>.

### BCC calculation

The BCC messages sent by the transmitter is calculated as the XOR of all the bytes of the message (excluding <cr> and <lf>) and divided into two nibbles.

The two nibbles are then transformed into their ASCII codes.

The BCC transmitted at the end of record is used to check the validity of records received.

## CURRENT LOOP

Command format: ID + L + x <cr>

Example: if ID=14 and you want to enable the current loop type 14L0 <cr> or 00L0 <cr>

Response of the unit: <lf> ID + L + x <cr> <lf>                      command executed correctly

Response of the unit: none    command failed

It is possible to enable or disable the current loop in the configuration menu by selecting:

x=0 current loop disabled

x=1 current loop enabled

## SENSOR CURRENT

Command format: ID + F + x <cr>

Example: if ID=14 and the nominal current is 160 nA/ppm (low current) type 14F1 <cr> or 00F1 <cr>

Response of the unit: <lf> ID + F + x <cr> <lf>                    command executed correctly  
Response of the unit: none    command failed

The current of the sensor can be set with the following values:

x=1 LO current (160 mA/ppm)

x=2 HI current (2000 nA/ppm)

## POLARIZATION VOLTAGE

Command format: ID + P + x <cr>

Example: if ID=14 and the polarization voltage is -200 mV type 14P-200 <cr> or 00P-200 <cr>

Response of the unit: <lf> ID + P + x <cr> <lf>                    command executed correctly  
Response of the unit: none    command failed

The polarization voltage to use will depend by the sensor type and the application.

## MEASURING UNIT

Command format: ID + M + x <cr>

Example: if ID=14 and the measuring unit in ppm type 14M1 <cr> or 00M1 <cr>

Response of the unit: <lf> ID + M + x <cr> <lf>                    command executed correctly  
Response of the unit: none    command failed

The measuring unit can be set with the following values:

x=1 ppm

x=2 mg/l

## ANALOG OUTPUT

Command format: ID + O + x <cr>

Example: if ID=14 and analog out = 200.0 ppm type 14O3 <cr> or 00O3 <cr>

Response of the unit: <lf> ID + O + x <cr> <lf>                    command executed correctly  
Response of the unit: none    command failed

The 4-20 mA analog output can be assigned to one of the three following scales.

x=1 for 2.000 ppm / mg/l scale

x=2 for 20.00 ppm / mg/l scale

x=3 for 200.0 ppm / mg/l scale

## SCALE FACTOR

Command format: ID + X + x <cr>

Example: if ID=14 and the scale factor is 50 % type 14X50 <cr> or 00X50 <cr>

Response of the unit: <If> ID + x + x <cr> <If>                    command executed correctly  
Response of the unit: none    command failed

To verify the receiving of the value type ID + H.  
Examples of scales factors selection:

Scale factor	full scale
100 %	2/20/200 ppm
50 %	1/10/100 ppm
25 %	0,5/5/50 ppm
10 %	0.2/2/20 ppm

## LARGE FILTER

Command format: ID + RL + x <cr>

Example: if ID=14 and the response time is 5 seconds type 14RL5 <cr> or 00RL5 <cr>

Response of the unit: <If> ID + RL + x <cr> <If>                    command executed correctly  
Response of the unit: none    command failed

To check whether the entered value has been received type command ID + H.

## SMALL FILTER

Command format: ID + RS + x <cr>

Example: if ID=14 and the response time is 5 seconds type 14RS5 <cr> or 00RS5 <cr>

Response of the unit: <If> ID + RS + x <cr> <If>                    command executed correctly  
Response of the unit: none    command failed

To check whether the entered value has been received type command ID + H.

## SMALL FILTER

Command format: ID + G + x <cr>

Example: if ID=14 and the function for hide negative has to be enabled type 14G1 <cr>  
or 00G1 <cr>

Response of the unit: <If> ID + G x <cr> <If>                    command executed correctly  
Response of the unit: none    command failed

To check whether the entered value has been received type command ID + H.

Set parameter:

x=0 for enable the function

x=1 for disable the function

## TEMPERATURE MEASURING UNIT

Command format: ID + W + x <cr>

Example: if ID=14 and the unit of measurement of the temperature is °C type 14W1 <cr> or 00W1 <cr>

Response of the unit: <lf> ID + W + x <cr> <lf>                      command executed correctly

Response of the unit: none    command failed

The temperature measuring unit can be configured with the following values:

x=1    measuring unit °C

x=2    measuring unit °F

## TEMPERATURE CALIBRATION

Command format: ID + J + x <cr>

Example: if ID=14 and the temperature value is 23.2 °C type 14J23.2 <cr> or 00J23.2 <cr>

Response of the unit: <lf> ID + J + x <cr> <lf>                      command executed correctly

Response of the unit: none    command failed

Zero adjustment of the temperature measure.

To verify the results of the temperature correction use the ID + A, the temperature reading should be approx. same as the adjusted value.

With the command ID + H control the line "Temp. adjust: ok / error".

With the command ID + J? you can read the result directly.

If the operation has failed (error) the previous zero value is retained.

The "Temp. adjust: not done" message indicates that the parameter has been restored to the default value with the command ID + JR.

## TEMPERATURE CALIBRATION RESET

Command format: ID + JR <cr>

Example: if ID=14 type 14JR <cr> or 00JR <cr>

Response of the unit: <lf> ID + JR <cr> <lf>                      command executed correctly

Response of the unit: none    command failed

This command allows you to return the value of the zero temperature to the default value.

Verify the outcome of the operation with the command ID + H and check the line "Temp. adjust: not done".

## TEMPERATURE CALIBRATION TEST

Command format: ID + J? <cr>

Example: if ID=14 type 14J? <cr> or 00J? <cr>

Response of the unit: <8 characters outcome> command executed correctly  
<blank> <7 digit value> <4 characters unit> <cr> <lf>

Response of the unit: none command failed

### Record format

```
ok      ±    0.2°C  
.....+.....|.....+.....|.....+.....|.....+.....|.....+.....|.....+.....|.....+.....|
```

The possible results are: ok / not done / error.

## MANUAL TEMPERATURE

Command format: ID + N + x <cr>

Example: if ID=14 and the manual temperature is 28.3 °C type 14N28.3 <cr> or 00N28.3 <cr>

Response of the unit: <lf> ID + N + x <cr> <lf> command executed correctly

Response of the unit: none command failed

To check whether the entered value has been received type command ID + H.

## TEMPERATURE COEFFICIENT

Command format: ID + C + x <cr>

Example: if ID=14 and the TC is 2.10 %/°C type 14C2.10 <cr> or 00C2.10 <cr>

Response of the unit: <lf> ID + C + x <cr> <lf> command executed correctly

Response of the unit: none command failed

To check whether the entered value has been received type command ID + H.

## ZERO CALIBRATION SOLUTION VALUE

Command format: ID + V + x <cr>

Example: if ID=14 and the standard solution value is 0.12 ppm type 14V0.12 <cr> or 00V0.12 <cr>

Response of the unit: <lf> ID + V + x <cr> <lf> command executed correctly

Response of the unit: none command failed

To check whether the entered value has been received type command ID + H.

## SENSITIVITY CALIBRATION SOLUTION VALUE

Command format: ID + T + x <cr>

Example: if ID=14 and the standard solution value is 18.12 ppm type 14T18.12 <cr> or 00T18.12 <cr>

Response of the unit: <lf> ID + T + x <cr> <lf>                    command executed correctly  
Response of the unit: none    command failed

To check whether the entered value has been received type command ID + H.

## ZERO CALIBRATION

The zero calibration must be done in a solution without oxidizers or in a known solution. The value of the zero solution must be inserted into the instrument through the command "Zero cal value".

The zero calibration is carried out in the scale selected and the same offset will be applied to the other scales.

Command format: ID + Z <cr>

Example: if ID=14 type 14Z <cr> or 00Z <cr>

Response of the unit: <lf> ID + Z <cr> <lf>                    command executed correctly  
Response of the unit: none    command failed

To verify the results of the zero calibration use the ID + A.

With the command ID + H control the line "Zero calibration: ok / error ".

With the command ID + Z ? you can read the result directly.

If the operation has failed (error), the previous zero value is retained.

Check if the sensor is perfectly clean.

The message "Zero calibration: not done" indicates that the parameter has been restored to the default value with the command ID + ZR.

## ZERO CALIBRATION RESET

Command format: ID + ZR <cr>

Example: if ID=14 type 14ZR <cr> or 00ZR <cr>

Response of the unit: <lf> ID + ZR <cr> <lf>                    command executed correctly  
Response of the unit: none    command failed

This command allows you to restore the zero value to the default values.

Verify the outcome of the operation with the ID + H and check the line "Zero calibration: not done".

## ZERO CALIBRATION TEST

Command format: ID + Z? <cr>

Example: if ID=14 type 14Z? <cr> or 00Z? <cr>

Response of the unit: <8 characters outcome>                      command executed correctly  
                                  <blank> <7 digit value> <4 characters unit> <cr> <lf>

Response of the unit: none    command failed

### Record format

```
ok          ± 1000nA
.....+.....|.....+.....|.....+.....|.....+.....|.....+.....|.....+.....|.....+.....|
```

Possible results: ok / not done / error.

## SENSITIVITY CALIBRATION

The sensitivity calibration is done in a known solution.

The value of the solution should be inserted through the commands "Set standard solution" and "Set standard measure unit".

The calibration is performed on the selected scale and the new sensitivity value will also be applied to the other scales.

Command format: ID + S <cr>

Example: if ID=14 type 14S <cr> or 00S <cr>

Response of the unit: <lf> ID + S <cr> <lf>                      Command executed correctly

Response of the unit: none    Command failed

To verify the results of the calibration, use the ID + A; the reading should be about the value of the calibration solution.

Through the command ID + H the user controls line: "Sens calibration: OK/error".

Through the command ID + S? the user can read the result directly.

If the calibration has failed (error) check that the cell is properly immersed in the solution.

Check the state of the surfaces of the measuring cell, if necessary, clean them with a soft cloth.

In case of failure the transmitter resets its previous sensitivity.

The message "Sens. calibration: not done" indicates that the parameter has been restored to the default value through the command ID + SR.

## SENSITIVITY CALIBRATION RESET

Command format: ID + SR <cr>

Example: if ID=14 type 14SR <cr> or 00SR <cr>

Response of the unit: <lf> ID + SR <cr> <lf>                      command executed correctly

Response of the unit: none    command failed

This command allows to return to the default sensitivity value of 100.0 %.  
Verify the outcome of the operation through the command ID + H and check the line "Sens. calibration: not done".

## SENSITIVITY CALIBRATION TEST

Command format: ID + S? <cr>

Example: if ID=14 type 14S? <cr> or 00S? <cr>

Response of the unit: <8 characters outcome>                      command executed correctly  
                                 <blank> <7 digit value> <4 characters unit> <cr> <lf>

Response of the unit: none    command failed

### Record format

```
ok            ± 100.0%  
.....+.....|.....+.....|.....+.....|.....+.....|.....+.....|.....+.....|.....+.....|
```

Possible results: ok / not done / error.

## LAST CALIBRATION DATE

Command format: ID + D + XX/XX/XX <cr> (XX = 00 ÷ 99)

Example: if ID=14 and the date to be inserted is 11/05/18 type 14D11/05/18 <cr> or 00D11/05/18 <cr>

Response of the unit: <cr> <lf> ID + D + XX/XX/XX <cr>      command executed correctly  
                                 <lf>

Response of the unit: none    command failed

This command allows to store the last calibration date.  
The date field is 8 characters to be written in the proposed format.

## ID OF THE B&C PROTOCOL

Command format: ID + I + x <cr>

Example: if ID=14 and the new ID (identification) to enter is 07 type 14I07 <cr> or 00I07 <cr>

Response of the unit: <lf> ID + I + x <cr> <lf>                      command executed correctly

Response of the unit: none    command failed

The transmitter activates the new ID immediately after the response to the command.

## ID OF THE MODBUS PROTOCOL

Command format: ID + E + x <cr>

Example: if ID=14 and the new ID (identification) to enter is 07 type 14E07 <cr> or 00E07 <cr>



Response of the unit: <6 characters code> <2 characters ID> <6 characters serial number> <2 characters BCC>  
<cr> <lf> command executed correctly

Response of the unit: none command failed

```
CL3436,14,123456,xx  
.....+.....|.....+.....|
```

This command allows to search all the transmitters in a network.

The transmitters respond by providing their identity: code, ID, serial number.

The transmitter response occurs after a random time chosen by the transmitter itself between 8 time intervals: 0 ms, 200 ms, 400 ms, 600 ms, 800 ms, 1000 ms, 1200 ms, 1400 ms to avoid as much as possible an overlap of the answers when there are more transmitters on the network.

If there are more transmitters, some overlap of communication will be unavoidable.

The master device must manage the transmitters search by disabling the commands of the transmitters it has found, repeating the search command several times until it has found all the transmitters in the network.

At this point the master can re-enable the commands of the transmitters he has found. To disable and re-enable the transmitter commands, see the command ID + SNxxxxxx + MUX <cr>.

The automatic management of transmitters is implemented in the MC 6587 and MC 7687 instruments of the B&C Electronics.

## DISABLE/ENABLE COMMANDS USING ID

Command format: ID + SNxxxxxx + MUX <cr>

Example: to disable commands using ID of a transmitter with ID=14 and serial number 123456 type 14SN123456MU1 <cr> or 00SN123456MU1 <cr>

Response of the unit: <cr> <lf> ID + SNxxxxxx + MUX <cr> <lf> command executed correctly

Response of the unit: none command failed

Set parameter:

x=0 to enable commands using ID

x=1 to disable the commands using ID

When the transmitter is disabled to commands using ID:

- can only execute commands with ID + SNxxxxxx;
- does not run the transmitter search command ID + SN?.

## 6.9.2 MODBUS PROTOCOL

On the transmitter, in addition to the ASCII B&C protocol, is implemented the Modbus RTU protocol limited to the function 03, 06, and 16.

In Modbus communication network the transmitter operates as a slave device.

### RTU transmission mode

Coding system	8-bit binary
Number of bits per character:	
- start bits	1
- data bits (minus sign before)	8
- parity	no parity
- stop bits	1
Errors verification	CRC-16

### RTU messages format

Pause transmission	duration 3,5 bytes
Address	1 byte (8 bits)
Function	1 byte (8 bits)
Data	N bytes (N x 8 bits)
Errors verification	2 bytes (16 bits)
Pause transmission	duration 3,5 bytes

For a correct synchronization of the transmission the receiving unit interprets the end of a message when it doesn't receive any characters (bytes) for a time equivalent to the transmission of 3.5 characters (bytes).

## MODBUS FUNCTION 03 (0x03)

### Function 03 (MASTER QUERY)

Address	1 byte	1 ÷ 243 (transmitter ID)
Function	1 byte	03 (read holding register)
Start address data HI	1 byte	Start address of registers
Start address data LO	1 byte	
Number of registers HI	1 byte	Number of registers (2 byte x register)
Number of registers LO	1 byte	
Errors verification	2 bytes	CRC-16

The transmitter considers valid the message if CRC-16 valid, ID valid and function=03.  
Function 03 (SLAVE ANSWER)

Address	1 byte	1 ÷ 243 (transmitter ID)
Function	1 byte	03 (read holding register)
Number of byte of sent data	1 byte	2x number of sent registers
N byte of data	N byte	Values of registers
Error verification	2 bytes	CRC-16

If you query requesting registers outside the defined limits, the transmitter answers assigning zero to all of the registers out of range.

If an error occurs in the request, the response takes the following form:

Address	1 byte	1 ÷ 243 (transmitter ID)
Function	1 byte	0x83 (read holding register + error)
Error	1 byte	2 = illegal data address 3 = illegal data value
Error verification	2 bytes	CRC-16

Time between the end of the query and the beginning of the response about 100 ms.

## MODBUS FUNCTION 06 (0x06)

### Function 06 (MASTER QUERY)

Address	1 byte	1 ÷ 243 (transmitter ID)
Function	1 byte	06 (write single register)
Address data HI	1 byte	Address of the register
Address data LO	1 byte	
Value of the register HI	1 byte	Value to be written
Value of the register LO	1 byte	
Errors verification	2 bytes	CRC-16

The transmitter considers valid the message if CRC-16 valid, ID valid and function=06.  
Function 06 (SLAVE ANSWER)

Address	1 byte	1 ÷ 243 (transmitter ID)
Function	1 byte	06 (write single register)
Address data HI	1 byte	Address of the register
Address data LO	1 byte	
Value of the register HI	1 byte	Value to be written
Value of the register LO	1 byte	
Errors verification	2 bytes	CRC-16

When writing some calibration commands (eg zero calibration), the transmitter responds to the request and then remains silent for the time necessary to perform the operation.

If an error occurs in the request, the response takes the following form:

Address	1 byte	1 ÷ 243 (transmitter ID)
Function	1 byte	0x86 (write single register + error)
Error	1 byte	2 = illegal data address 4 = slave device failure
Error verification	2 bytes	CRC-16

Time between the end of the query and the beginning of the response about 100 ms.

## MODBUS FUNCTION 16 (0x10)

### Function 16 (MASTER QUERY)

Address	1 byte	1 ÷ 243 (transmitter ID)
Function	1 byte	16 (write multiple registers)
Start address data HI	1 byte	Start address of registers
Start address data LO	1 byte	
Number of registers HI	1 byte	Number of registers (2 byte x register)
Number of registers LO	1 byte	
Number of byte	1 byte	2 byte per register
Value of registers	n byte	n = 2 byte x number of registers
Errors verification	2 bytes	CRC-16

The transmitter considers valid the message if CRC-16 valid, ID valid and function=16.

### Function 16 (SLAVE ANSWER)

Address	1 byte	1 ÷ 243 (transmitter ID)
Function	1 byte	16 (write multiple registers)
Start address data HI	1 byte	Start address of registers
Start address data LO	1 byte	
Number of registers HI	1 byte	Number of registers (2 byte x register)
Number of registers LO	1 byte	
Errors verification	2 bytes	CRC-16

When writing some calibration commands (eg zero calibration), the transmitter responds to the request and then remains silent for the time necessary to perform the operation.

If an error occurs in the request, the response takes the following form:

Address	1 byte	1 ÷ 243 (transmitter ID)
Function	1 byte	0x90 (write multiple registers + error)
Error	1 byte	2 = illegal data address 3 = illegal data value 4 = slave device failure
Error verification	2 bytes	CRC-16

Time between the end of the query and the beginning of the response about 100 ms.

## BROADCAST COMMANDS

Modbus 06 and 16 queries can be made by the master in broadcast mode.

The broadcast mode consists in sending the message with the identifier 0, all the transmitters perceive the message and execute the command but do not respond to the master in order not to create conflicts.

## MODBUS REGISTERS

MEASURE AND STATE (address 0x00xx)

	Mod-bus address	Parameter	Range	Unit	Scale	Data type	R/W
1	0x0000	Measured value	0 ÷ 2000	a	a	IS	R
2	0x0001	Temperature °C	-100 ÷ 1100	0.1	-10.0 ÷ 110.0 °C	IS	R
3	0x0002	Temperature °F	140 ÷ 2300	0.1	14.0 ÷ 230.0 °F	IS	R
4	0x0003	Measuring unit	1 ÷ 2		1 = ppm 2 = mg/l	IS	R
5	0x0004	Scale	1 ÷ 3	b		IS	R
6	0x0005	Temperature coefficient	0 ÷ 400	0.01	0.01 ÷ 4.00 %/°C	IS	R
7	0x0006	State: Dig. Inp. Keyb. lock Man. temp.	0/1 0/1 0/1	1 bit0 bit1 bit2	open/close no hold/hold auto/man	I	R
8	0x0007	BCC EEPROM	0 ÷ 65535	1	0 ÷ 65535	I	R

<sup>a</sup> = unit and scale depend on what is set in configuration (see 4 and 5)

<sup>b</sup> = see chapter "Configuration (page 30)"

IS = integer signed / I = integer

R = read / W = write

ZERO CALIBRATION (address 0x010x)

	Mod-bus address	Parameter	Range	Unit	Scale	Data type	R/W
9	0x0100	Decimal point zero cal value	1 ÷ 3	1		IS	R/W
10	0x0101	Zero cal value - decimal point = 1 - decimal point = 2 - decimal point = 3	0 ÷ 2000 0 ÷ 2000 0 ÷ 2000	0.1 0.01 0.001	ppm / mg/l 0.0 ÷ 200.0 0.00 ÷ 20.00 0.000 ÷ 2.000	IS	R/W
11	0x0102	Zero command/flag - zero cal - reset zero - flag zero cal	0x5A00 0x5A52 0 = not done 1 = ok 2 = error	1 1 1		IS	W W R
12	0x0103	Zero value	-2000 ÷ 2000	1	-2000 ÷ 2000 nA	IS	R

IS = integer signed / I = integer

R = read / W = write

SENSIBILITY CALIBRATION (address 0x011x)

	Mod-bus address	Parameter	Range	Unit	Scale	Data type	R/W
13	0x0112	Decimal point sens cal value	1 ÷ 3	1		IS	R/W
14	0x0113	Sens cal value - decimal point = 1 - decimal point = 2 - decimal point = 3	0 ÷ 2000 0 ÷ 2000 0 ÷ 2000	0.1 0.01 0.001	ppm / mg/l 0.0 ÷ 200.0 0.00 ÷ 20.00 0.000 ÷ 2.000	IS	R/W
15	0x0114	Sens command/flag - sens cal - reset sens - flag sens cal	0x5300 0x5352 0 = not done 1 = ok 2 = error	1 1 1		IS	W W R
16	0x0115	Sens value	125 ÷ 2500	0.1	12.5 ÷ 250.0 %	IS	R

IS = integer signed / I = integer

R = read / W = write

**TEMPERATURE CALIBRATION (address 0x012x)**

	Mod-bus address	Parameter	Range	Unit	Scale	Data type	R/W
17	0x0120	Temp command/flag - reset temp - flag temp cal	0x4A52 0 = not done 1 = ok 2 = error	1 1		IS	W R
18	0x0121	Temp. adj  Temp zero value	-100 ÷ 1100 -140 ÷ 2300 -50 ÷ 50 -90 ÷ 90	0.1 0.1 0.1 0.1	-10.0 ÷ 110.0 °C -14.0 ÷ 230.0 °F -5.0 ÷ 5.0 °C -9.0 ÷ 9.0 °F	IS	W  R

IS = integer signed / I = integer

R = read / W = write

**SETUP (address 0x020x)**

	Mod-bus address	Parameter	Range	Unit	Scale	Data type	R/W
19	0x0200	Large filter	1 ÷ 20	1	1 ÷ 20 s	IS	R/W
20	0x0201	Small filter	1 ÷ 20	1	1 ÷ 20 s	IS	R/W

IS = integer signed / I = integer

R = read / W = write

**CL 3436 SETUP (address 0x021x)**

	Mod-bus address	Parameter	Range	Unit	Scale	Data type	R/W
21	0x0210	Temp unit	1 ÷ 2	1	1 = °C 2 = °F	IS	R/W
22	0x0211	Temp man	0 ÷ 1000 320 ÷ 2120	0.1	0.0 ÷ 100.0 °C 32.0 ÷ 212.0 °F	IS	R/W
23	0x0212	Coeff. temp.	0 ÷ 400	0.01	0.00 ÷ 4.00 %/°C	IS	R/W

IS = integer signed / I = integer

R = read / W = write

CONFIGURATION (address 0x030x)

	Mod- bus ad- dress	Parameter	Range	Unit	Scale	Data type	R/W
24	0x0300	Current loop	0 ÷ 1	1	0 = disable 1 = enable	IS	R/W
25	0x0301	Scale	1 ÷ 3	1	a	IS	R/W
26	0x0302	Full scale scalability	10 ÷ 100	1	10 ÷ 100 %	IS	R/W
27	0x0303	Baud rate	1 ÷ 4	1	1 = 2400 2 = 4800 3 = 9600 4 = 19200	IS	R/W
28	0x0304	ID B&C	1 ÷ 99	1		IS	R/W
29	0x0305	ID Modbus RTU	1 ÷ 243	1		IS	R/W

<sup>a</sup> = see chapter "Configuration (page 30)"

IS = integer signed / I = integer

R = read / W = write

CL 3436 CONFIGURATION (address 0x030x)

	Mod-bus address	Parameter	Range	Unit	Scale	Data type	R/W
30	0x0310	Sensor current	1 ÷ 2	1	1 = LO current 2 = HI current	IS	R/W
31	0x0311	Polarization	-1000 ÷ 1000	1	-1000 ÷ 1000 mV	IS	R/W
32	0x0312	Measure unit	1 ÷ 2	1	1 = ppm 2 = mg/l	IS	R/W
33	0x0313	Hidden negative	1 ÷ 2	1	1 = OFF 2 = ON	IS	R/W

IS = integer signed / I = integer

R = read / W = write

INFO TRANSMITTER (address 0x040x)

	Mod-bus address	Parameter	Range	Unit	Scale	Data type	R/W
34	0x0401	Code	6 characters			I	R
35	0x0404	Serial number	6 characters			I	R
36	0x0407	Rev. fw	4 characters			I	R
37	0x0409	Last cal date (1)	00 ÷ 99	1		IS	R/W
38	0x040A	Last cal date (2)	00 ÷ 99	1		IS	R/W
39	0x040B	Last cal date (3)	00 ÷ 99	1		IS	R/W

IS = integer signed / I = integer

R = read / W = write

Use of BCC EEPROM

The EEPROM BCC check is the transmitter configuration state synthesis. After setting the parameters and carry out the calibration the value of the BCC remains constant until the next change of parameters or calibration.

A variation of BCC in the absence of changes warns that an alteration has taken place in the transmitter configuration data.

# 7 INSTALLATION DRAWINGS

## 7.1 CONNECTIONS

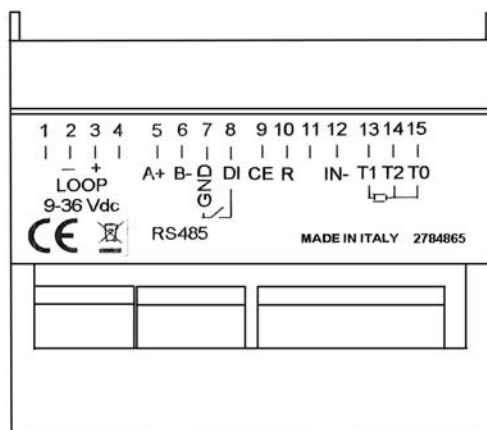

Terminal	Function
2	- Loop
3	+ Loop (9 ÷ 36 Vdc)
5	RS485 A+
6	RS485 B-
7	RS485 Gnd
7	Digital input
8	Digital input
9	Counter electrode input (anode) (jumper 9 - 10 for two electrodes cell)
10	Reference electrode input (jumper 9 - 10 for two electrodes cell)
12	Measuring electrode input (cathode)
13	Temperature sensor input
14	Common temperature sensor input
15	Common temperature sensor input

## 7.2 DIMENSIONS

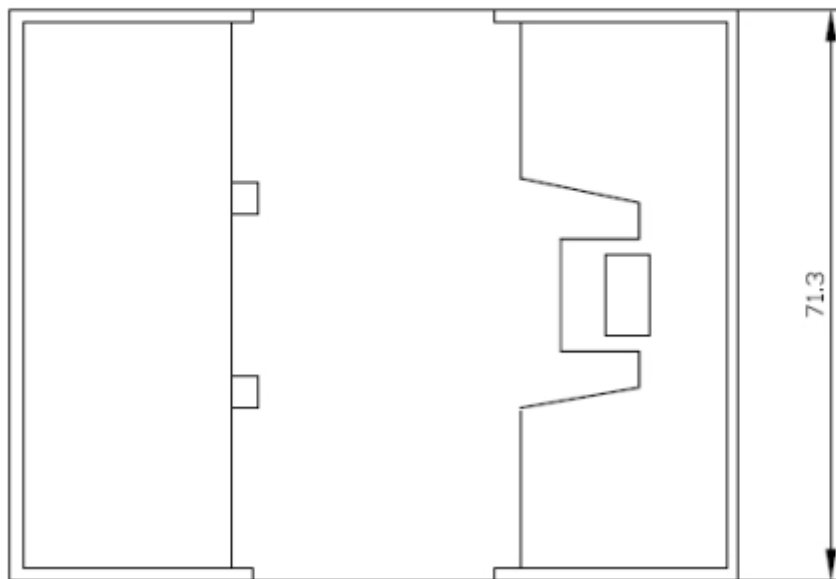
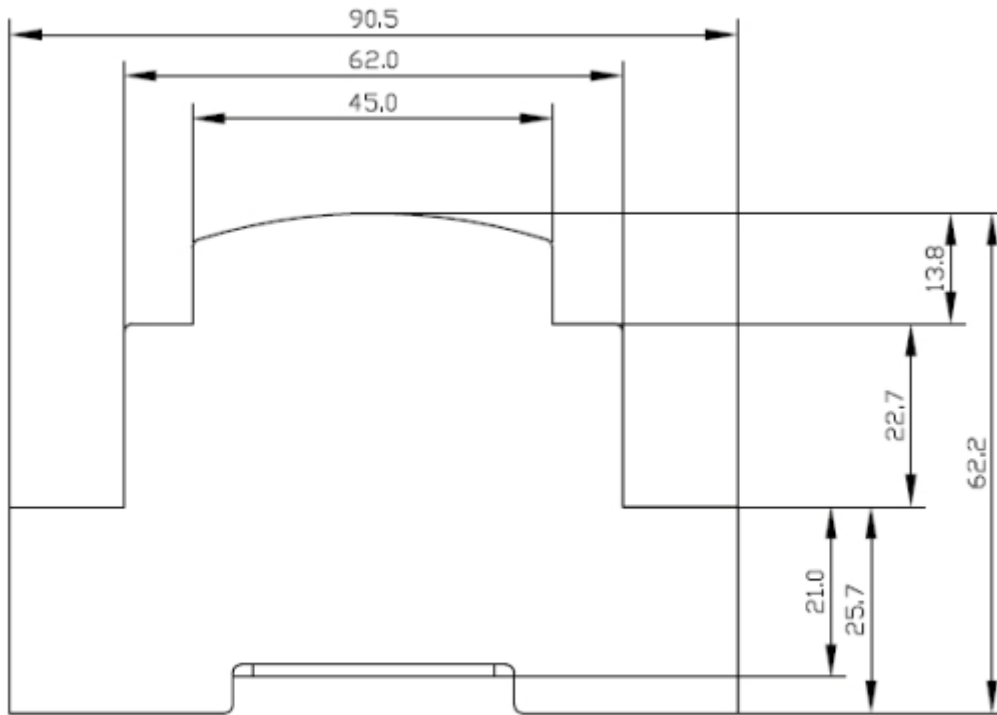

### 7.3 ANALOG MODE WIRING

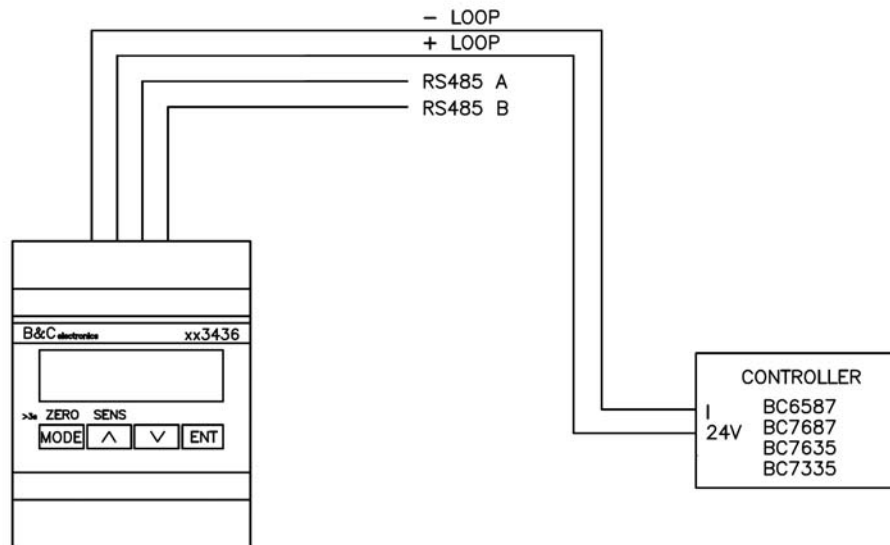

*Connection to B&C Electronics' instruments*

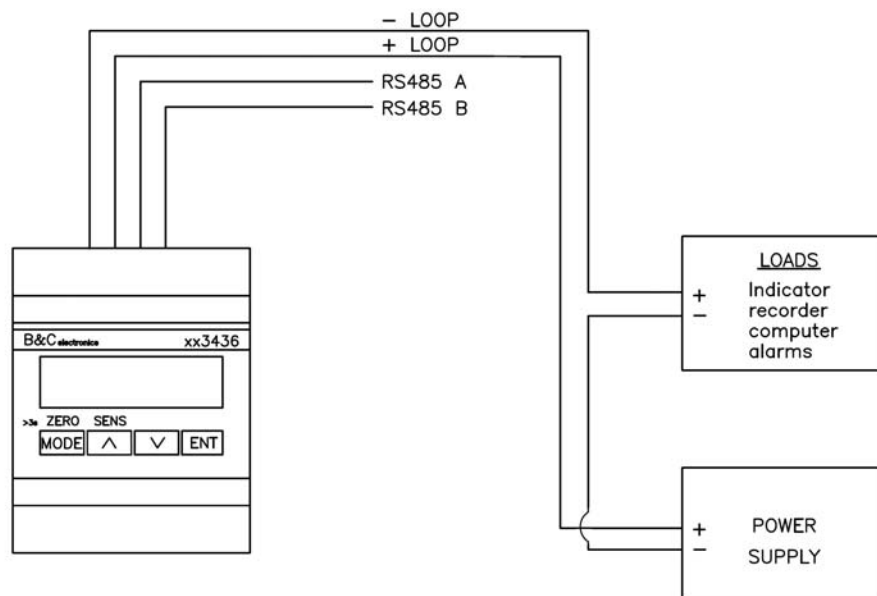

*Connection to PLC or data logger*

## 7.4 DIGITAL MODE WIRING

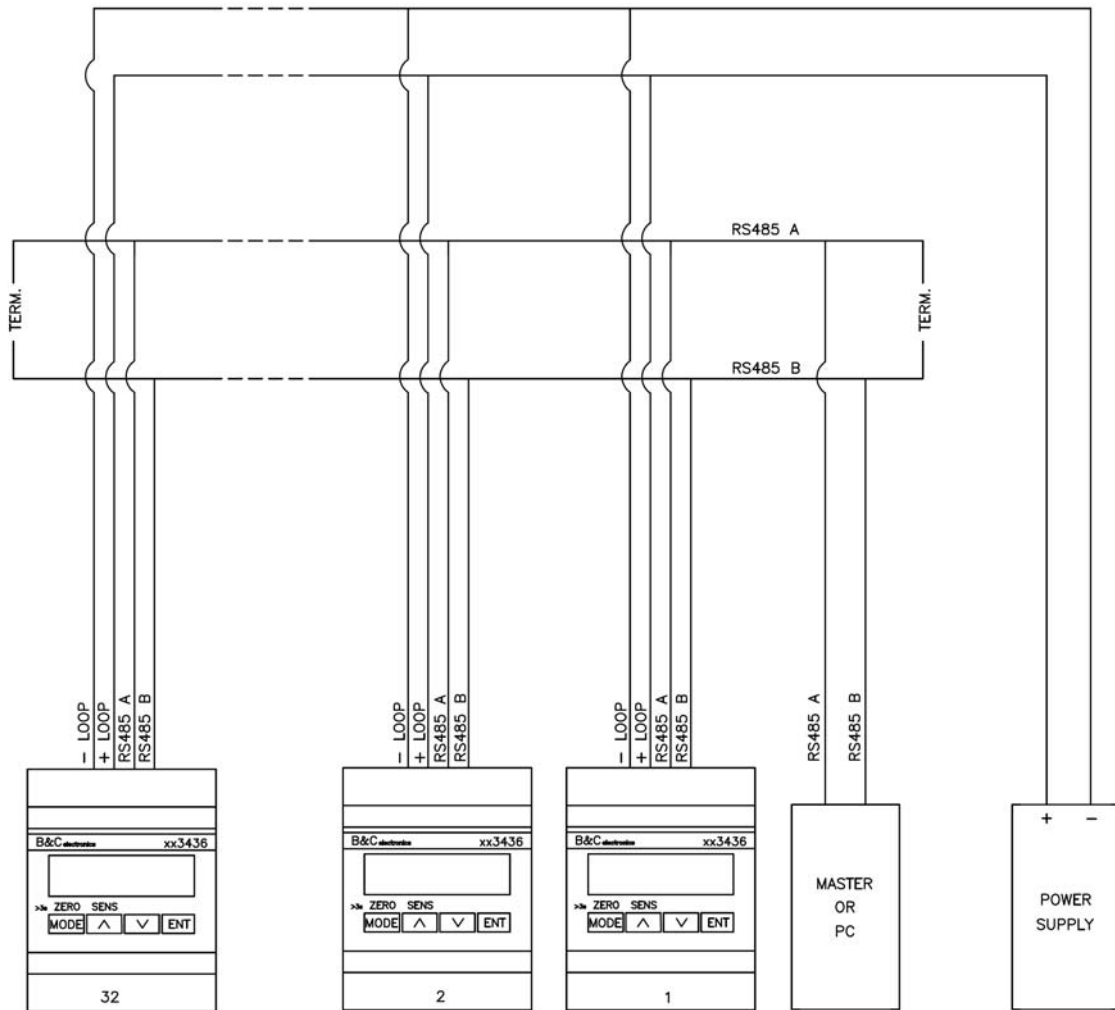

## 8 WARRANTY

- 1 Your product is guaranteed for 5 years from the date of purchase, for failure due to manufacturing defects.
  - 2 The warranty is void in case of tampering or deterioration due to improper installation or maintenance.
  - 3 The warranty covers only free repair at the laboratories of the manufacturer.
  - 4 B&C Electronics is not liable for any damage arising from misusing its instruments and products.
- 

## 9 REPAIRS

For faster and efficient service it is recommended to fill in the "Information card" for the repair service and attach it to a "Repair order".

- 1 The estimated cost, if required by the customer, is free if the repair is confirmed. Otherwise flat rate results in a charge for the analytical work performed and expenses incurred.
- 2 The products to be repaired must be sent to B&C Electronics with freight prepaid. Any expenses incurred on behalf of the client and not previously agreed will be charged.
- 3 Our sales department will submit to the customer the repair estimate or offer a replacement in the following cases:
  - repair cost is considered excessive in relation to the cost of the product;
  - the repair is technically impossible or unreliable.
- 4 In order to reduce the time of delivery of the repaired products, unless otherwise offered or arranged by the customer, the shipment will be made with ex-factory, prepaid carriage by a courier.

INFORMATION SHEET  
*for service repairs*

In the event of a fault, we recommend you contact our repair service, to photocopy and complete this information sheet to be attached to the product to be repaired.

ESTIMATE

REPAIR

---

COMPANY NAME

---

ADDRESS

ZIP

TOWN

---

REFER TO MR/MRS

TELEPHONE

---

MODEL

S/N

DATE

---

Consult the instruction manual to identify the area of the defect and/or describe it:

SENSOR

ANALOG OUTPT

POWER SUPPLY

SET POINT

CALIBRATION

RELAYS CONTACTS

DISPLAY

INTERMITTENT PROBLEM

---

DESCRIPTION OF THE DEFECT

. . . . .

. . . . .

. . . . .

. . . . .

. . . . .

. . . . .





**B&C Electronics s.r.l. – Via per Villanova 3 – 20866 Carnate (MB) – Italia**  
Tel. +39 039 631 721 – Fax +39 039 607 6099 – [bc@bc-electronics.it](mailto:bc@bc-electronics.it) – [www.bc-electronics.it](http://www.bc-electronics.it)