



## Instruction manual

# IC 6587.103

ION SELECTIVE - pH - ORP - CONDUCTIVITY CONTROLLER  
3 inputs - wall mounting

Option  
S/N  
REP N°

Power supply: 85/264 Vac  
Installed firmware: R 1.1x





# INDEX

<b>1 - GENERAL WARNINGS AND INFORMATION FOR ALL USERS</b>	<b>5</b>
1.1 Warranty .....	5
1.2 After sales service .....	5
1.3 CE marking .....	5
1.4 Safety warnings .....	5
1.5 Manual revisions .....	6
<b>2 - PRODUCT OVERVIEW</b>	<b>7</b>
2.1 Functional purpose .....	7
2.2 Accessories .....	8
<b>3 - INSTRUCTION MANUAL CONTENTS</b>	<b>9</b>
3.1 Symbols .....	9
3.2 How to read the instruction manual .....	9
3.2.1 Using the instrument on the plant .....	10
3.2.2 Plant maintenance .....	10
3.2.3 Instrument installation .....	12
<b>4 - SPECIFICATIONS AND TECHNICAL DATA</b>	<b>16</b>
4.1 Functional specification .....	16
4.2 Technical data .....	22
4.2.1 General specifications .....	22
4.2.2 Technical specification .....	23
<b>5 - INSTALLATION</b>	<b>48</b>
5.1 Packing list .....	48
5.2 Packing and unpacking .....	48
5.3 Storage and transport .....	48
5.4 Installation .....	48
5.4.1 Wall mounting instructions .....	48
5.5 Installation of the sensors .....	49
5.6 Electrical installation .....	49
5.6.1 Connecting to the mains .....	50
5.6.2 Connecting the conductivity cell to the input A .....	50
5.6.3 Connecting the sensors to input B and C .....	51
5.6.4 Connecting the temperature sensor .....	51
5.6.5 Connecting the analog outputs .....	52
5.6.6 Connecting the serial port RS 485 .....	52
5.6.7 Connecting pumps, solenoids and alarms .....	52
5.6.8 Connecting the logic inputs .....	54
5.6.9 Network connection (RS485) .....	54

5.7 Disposal .....	55
<b>6 - OPERATING PROCEDURE</b> .....	<b>56</b>
6.1 Measurement of the concentration of specific ions .....	56
6.2 Measurement of the pH and ORP .....	57
6.3 Measurement of the conductivity .....	57
6.4 Measurement of the pure water conductivity .....	58
6.5 Measurement of the TDS .....	58
6.6 Indirect measurement of the concentration .....	59
6.7 Measurement of the resistivity .....	60
6.8 Display .....	61
6.9 Keyboard .....	61
6.10 Users instruction .....	62
6.10.1 Main display .....	62
6.10.2 Input A measuring .....	62
6.10.3 Input B measuring .....	63
6.10.4 Input C measuring .....	63
6.11 Temperature measuring .....	63
6.11.1 Analog output 1 values .....	64
6.11.2 Analog output 2 values .....	64
6.11.3 Autoclean .....	64
6.11.4 Parameters for the maintenance .....	65
6.11.5 Parameters for the plant engineer .....	65
6.11.6 Information menu .....	65
6.12 Maintenance instruction .....	66
6.12.1 Preliminary operations .....	66
6.12.2 Measuring operations .....	66
6.12.3 Calibration .....	67
6.12.4 Calibration of the conductivity (input A) .....	67
6.12.5 .....	67
6.12.6 TDS calibration .....	69
6.12.7 Indirect measure calibration .....	69
6.12.8 ISE calibration (inputs B and C) .....	70
6.12.9 pH calibration (inputs B and C) .....	72
6.12.10 ORP calibration (inputs B and C) .....	74
6.12.11 Temperature calibration .....	76
6.12.12 Set point .....	76
6.12.13 Setup .....	77
6.12.14 Maintenance .....	80
6.12.15 Maintenance of sensors .....	80
6.13 Installation instruction .....	81
6.14 .....	81
6.14.1 Safety requirements .....	81
6.14.2 Configuration .....	81
6.15 Digital operation .....	87
6.15.1 B&C ASCII communication protocol .....	87
6.15.2 Modbus protocol .....	90

---

<b>7 - INSTALLATION DRAWINGS</b>	<b>97</b>
<hr/>	
7.1 Connection diagram .....	97
7.2 Dimensions and installation .....	98
<b>8 - WARRANTY</b>	<b>100</b>
<hr/>	
<b>9 - REPAIRS</b>	<b>100</b>
<hr/>	



# 1 GENERAL WARNINGS AND INFORMATION FOR ALL USERS

## 1.1 WARRANTY

This product is guaranteed for 5 years from the date of purchase for all manufacturing defects.

Please take a look at the terms and conditions described on the warranty certificate at the end of the manual.

## 1.2 AFTER SALES SERVICE

B&C Electronics offers to all of its customers the following services:

- a free of charge technical assistance over the phone and email for problems regarding installation, calibration and regular maintenance;
- a repairing service in our Carnate (Italy) headquarter for all types of damages, calibration or for a scheduled maintenance.

Please take a look at the technical support data sheet at the end of the manual for more details.

## 1.3 CE MARKING

This instrument is manufactured according to the following european community directives:

- 2011/65/EU "Restriction of the use of certain hazardous substances in electrical and electronic equipment"
- 2014/35/EU "Low Voltage" LV
- 2014/30/EU "Electromagnetic compatibility" EMC
- EN 61010-1/2011 "Low Voltage" LV
- EN 61326-1/2013 "Electromagnetic compatibility" EMC
  - Industrial electromagnetic environment
- EN 55011/2009 "Radio-frequency disturbance characteristics"
  - Class A (devices for usage in all establishment other than domestic)
  - Group 1 (Industrial equipment that do not exceed 9kHz)

The **CE** marking is placed on the packaging and on the S/N label of the instrument.

## 1.4 SAFETY WARNINGS

It should be remembered that electronic instruments can be subject to accidental failures.

Their use must be carried out with all the necessary precautions in order to avoid any damage caused by their dysfunction.

Any operation must be performed by authorized and trained staff.

The use of this controller must comply with the parameters described in chapter "Technical data (page 22)", in order to avoid potential damages and a reduction of its operating life.

## 1.5 MANUAL REVISIONS

This chapter shortly describes the differences between previously released versions of the same manual, so to help users that are already familiar with the product.

Rev. A: first release.

## 2 PRODUCT OVERVIEW

### 2.1 FUNCTIONAL PURPOSE

This instrument allows to measure simultaneously:

- conductivity/TDS/resistivity
- pH/ORP/Ion specific electrode (ISE)
- pH/ORP/Ion specific electrode (ISE)
- temperature

In case of use of a single sensor or two sensors, the instrument presents the related data, messages and functions, together with the temperature value.

- The firmware controls the self-cleaning function of the sensors by means of an external device and the self-calibration function of the ISE sensors by means of a chemical module.

The basic system for monitoring the above parameters consists of:

- the meter / regulator covered by this instruction manual;
- the measuring probes / sensors for each specific parameter.

The instrument contains the electronic circuitry and firmware to perform the following functions:

- view the measurement of the parameters detected by the connected sensors on the main display;
- perform automatic or manual temperature compensation in conductivity, pH and ISE measurements;
- automatically adjust the values of the main measurements, if appropriate dosing pumps or solenoid valves are connected to the output relays or analog outputs;
- provide an alarm if the measurement values are outside the established minimum and maximum limits or if the relays remain activated for longer than the established time;
- provide an alarm if the reagents for self-calibration of the ISE sensors are almost exhausted;
- provide two analog output signals for recording or acquiring the main measurements or the temperature or for PID regulation of the main measurements;
- provide an output type with RS 485 interface with B&C (ASCII) and Modbus RTU protocol;
- activate the alarm or maintain the status of the instrument outputs during maintenance / calibration operations using two external contacts;
- activate automatic or manual sensor cleaning cycles;
- activate periodic self-calibration of the ISE sensors.

Pumps or valves can be activated directly by the instrument or by external control switches if their power load is not compatible with the instrument's relays.

## 2.2 ACCESSORIES

Sensors and accessories for different applications are available, to be ordered separately.

Our web site [www.bc-electronics.it](http://www.bc-electronics.it) contains accessories, upgrades and detailed specifications of each product.

Our staff is always available to help costumers select the most appropriate and suitable solution for their specific needs.

## 3 INSTRUCTION MANUAL CONTENTS

This chapter describes the manual and gives suggestions to all users on how to read it and use it.

The manual is written according to the following norms:

- UNI 10893 "Instructions for use";
- UNI 10653 "Quality of product technical documentation".

The terminologies indicated in the international metrology vocabulary (VIM) are respected as far as possible.

### 3.1 SYMBOLS

Throughout the manual you may find the following symbols, which are both dictated by a norm or that are simply conventional.



**WARNINGS:** this symbol is used to warn users that if the instructions are ignored or not correctly followed, damage to the instrument can be caused.



**NOTE:** *this symbol is to invite the user to pay particular attention to a specific section of the manual.*

### 3.2 HOW TO READ THE INSTRUCTION MANUAL

The manual contains all the information needed to acquire full knowledge of the product, to ensure a proper installation, proper use and maintenance in order to achieve the desired result at the time of its choice.

The manual is aimed at staff with appropriate knowledge and experience in the field of measurement and control through the use of sensors and transmitters in the context of industrial plants.

The index of the manual refers the reader to the chapters on aspects that want to learn and develop.

In particular, the first chapters show general topics and allow the user to become familiar with the product and its functional purpose.

The user can then check whether he knows all the elements necessary for the use of the instrument and of the measuring/control.

The instrument and the instruction manual have been designed keeping in mind three different levels of use: end user, maintenance staff, system integrator or plant engineer.

-  *The user normally can read the values on the display.  
He will read the parts of the manual regarding the:*
- *"Users instruction (page 62)".*

*Maintenance staff could be more interesting in the chapters regarding:*

- *"Users instruction (page 62)";*
- *;*
- *"Warranty (page 100)";*
- *"Repairs (page 100)".*

*The plant engineer will have to read the chapters and look at the application drawings in order to:*

- *verify that the technical and functional characteristics are conformed with the plants requirements;*
- *verify that the environmental and climatic conditions required by the instruments are respected;*
- *make the correct electrical connections;*
- *become familiar with the instrument's firmware;*
- *configure the instrument according to the application;*
- *run all of the necessary tests before starting the instrument;*
- *calibrate the instrument once the sensor is connected.*

-  *The data shown in the display drawings in this manual are only illustrative.*

### 3.2.1 USING THE INSTRUMENT ON THE PLANT

For the generic use, the end user can operate with a locked keyboard (suggested mode to be set by maintenance staff). By this, he can check the set point parameters without the possibility of changing the configured set points values and the zero/sensitivity calibration.

### 3.2.2 PLANT MAINTENANCE

Maintenance staff can select the operating values, by setting the desired parameters of the setup menu after inserting the password. He can also enable the user's access to calibration, set point and alarm settings.

The location of those parameters can be seen in the left column of the technical specifications table and they are identified by a letter "S" followed by a number.

The operations to be done during the start-up and the periodical tests are the following.

#### Setup of the system

- password to access;
- to disable the calibration of the instrument and of the set points to the user;
- °C or °F temperature scale selection;

- manual temperature;
- logic inputs enabling;
- autoclean enabling;
- repetition, cleaning and holding time of the autocleaning;
- password modification.

#### Setup of the input A

- manual pH compensation value (*if ON*);
- temperature reference
- temperature coefficient;
- set point 1 hysteresis (ON-OFF);
- set point 1 delay (ON-OFF);
- set point 1 integration time:
- set point 1 derivation time;
- set point 1 proportional band;
- set point 1 pulse frequency FM;
- set point 1 pulse width WM;
- set point 2 hysteresis (ON-OFF);
- set point 2 delay (ON-OFF);
- set point 2 integration time:
- set point 2 derivation time;
- set point 2 proportional band;
- set point 2 pulse frequency FM;
- set point 2 pulse width WM;
- alarm LO;
- alarm HI;
- alarm delay.

#### Setup of the inputs B and C

- manual temperature setting (if ON);
- thermocompensation ON or OFF (ISE only);
- setting the temperature coefficient (*ISE only*);
- setting the isopotential point (ISE only);
- set point 1 hysteresis (ON-OFF);
- set point 1 delay (ON-OFF);
- set point 1 integration time:
- set point 1 derivation time;
- set point 1 proportional band;
- set point 1 pulse frequency FM;
- set point 1 pulse width WM;
- set point 2 hysteresis (ON-OFF);
- set point 2 delay (ON-OFF);

- set point 2 integration time;
- set point 2 derivation time;
- set point 2 proportional band;
- set point 2 pulse frequency FM;
- set point 2 pulse width WM;
- alarm LO;
- alarm HI;
- alarm delay;
- degasing function (ON OFF MANUAL)
- degasing time;
- hold time;
- calibration function;
- repetition time PT1;
- TP2 repetition time;
- pump delay;
- calibration time;
- hold time;
- standard solution 1;
- max displacement correction;
- standard solution 2;
- standard volume control (ON OFF);
- standard volume 1;
- standard volume 2;
- pump flow;
- volume control of ISA solution (ON OFF);
- ISA solution volume;
- ISA solution pump flow rate.
- 

### 3.2.3 INSTRUMENT INSTALLATION

The plant engineer, by inserting the access password and by setting and modifying the configuration parameters, will be able to select the necessary functions required by the plant.

The firmware allows the separate access to the configuration of the system and the configuration of the other main measures.

The location of this set parameters can be seen in the left column of the technical specifications table and they are identified by a letter "C" followed by a number.

The operations that need to be done during the instrument installation are the following.

#### System configuration

- password to access;

- operating mode (AUTO/MEAS/SIM);
- input A: (OFF / CONDUCTIVITY)
- input B: ( OFF / ISE / pH / ORP)
- input C: ( OFF / ISE / pH / ORP)
- temperature sensor Pt100 or Pt1000;
- relay 1 function;
- relay 2 function;
- relay 3 function;
- relay 4 function;
- contacts function (if relay 3 is dedicated to the alarm);
- analog output 1 addressed to A,B,C input or SET 1 / SET 2;
- analog output 2 addressed to A,B,C input or SET 1 / SET 2;
- logic input 1 function;
- logic input 2 function;
- baud rate;
- ID of the B&C protocol;
- Modbus address;
- password modification.

#### Input A configuration

- type of measurement: CONDUCTIVITY / INDIRECT MEASUREMENT or TDS / RESISTIVITY;
- K of cell;
- conductivity scale;
- TDS scale;
- EC / TDS conversion factor;
- indirect unit of measurement;
- custom unit of measure;
- decimal point of the indirect measurement;
- scale of indirect measurement;
- indirect measure table;
- resistivity measurement: ON / OFF;
- large software filter;
- small software filter.
- manual temperature: ON / OFF;
- manual temperature value;
- thermocompensation: COEFFICIENT / TABLE;
- value of the temperature coefficient;
- type of set point 1 regulation (if combined with relay): ON / OFF - PID;
- adjustment of set point 1 (if combined with a relay and PID): FM / WM;
- function of set point 1: LO / HI;
- type of set point 2 control (if combined with relay): ON / OFF - PID;

- adjustment of set point 2 (if combined with a relay and PID): FM / WM;
- function of set point 2: LO / HI;
- set point 1 permanence alarm: ON / OFF;
- residence time of set point 1;
- set point 2 permanence alarm: ON / OFF;
- residence time of set point 2;
- input combined with analogue output 1: EC / TDS / ° C / ° F;
- range of analogue output 1;
- point 1 of analogue output 1;
- point 2 of analogue output 1;
- input combined with analogue output 2; EC / TDS / ° C / ° F;
- range of analogue output 2;
- point 1 of analogue output 2;
- point 2 of analogue output 2.

#### Input B / C configuration

- type of ion ISE;
- unit of measure;
- measurement scale;
- manual temperature: ON / OFF;
- ISE thermocompensation: ON / OFF;
- ISE temperature coefficient;
- isopotential point ISE;
- type of set point 1 regulation (if combined with relay): ON / OFF - PID;
- adjustment of set point 1 (if combined with a relay and PID): FM / WM;
- function of set point 1: LO / HI;
- type of set point 2 control (if combined with relay): ON / OFF - PID;
- adjustment of set point 2 (if combined with a relay and PID): FM / WM;
- function of set point 2: LO / HI;
- set point 1 permanence alarm: ON / OFF;
- residence time of set point 1;
- set point 2 permanence alarm: ON / OFF;
- residence time of set point 2;
- input combined with analogue output 1: ppm / pH / mV / ° C / ° F;
- range of analogue output 1;
- point 1 of analogue output 1;
- point 2 of analogue output 1;
- input combined with analogue output 2: ppm / pH / mV / ° C / ° F;
- range of analogue output 2;
- point 1 of analogue output 2;
- point 2 of analogue output 2.
- -----

- type of measurement: pH / ORP;
- pH sensor type: glass / antimony / external 4-20 mA;
- large signal software filter;
- small signal software filter;
- type of set point 1 regulation (if combined with relay): ON / OFF - PID;
- adjustment of set point 1 (if combined with a relay and PID): FM / WM;
- function of set point 1: LO / HI;
- type of set point 2 control (if combined with relay): ON / OFF - PID;
- adjustment of set point 2 (if combined with a relay and PID): FM / WM;
- function of set point 2: LO / HI;
- set point 1 permanence alarm: ON / OFF;
- residence time of set point 1;
- set point 2 permanence alarm: ON / OFF;
- residence time of set point 2;
- input combined with analogue output 1: pH / mV ° C / ° F;
- range of analogue output 1;
- point 1 of analogue output 1;
- point 2 of analogue output 1;
- input combined with analogue output 2; pH / mV ° C / ° F;
- range of analogue output 2;
- point 1 of analogue output 2;
- point 2 of analogue output 2.
-

## 4 SPECIFICATIONS AND TECHNICAL DATA

### 4.1 FUNCTIONAL SPECIFICATION

#### Display

The instrument is equipped with a graphic display that shows the values of the measures and messages to the operator in the various stages of use of the unit.

At the top left it is shown the ID number related to the technical specifications.

In case of inactivity, after 3 minutes the unit turns to the main display.

The A, B and C measures display can stay active by pressing the key DOWN.

The brightness and contrast of the screen can be changed. The mode of presentation "reverse" can be chosen.

#### Keyboard

The instrument has a keyboard with 8 keys which allow access to all functions available.

The functions of the upper part of the keys, are dedicated to the calibration of the zero and sensitivity and the setting of the set point; these actions can be password protected in the setup menu.

For the functions of other buttons, see next paragraphs and chapters.

#### Inputs

The instrument is able to perform the measurement of three main parameters and temperature.

- Input A is exclusively dedicated to the measurement of conductivity by means of cells with 2 or 4 electrodes.
- Inputs B and C can be assigned to measure specific ions (ISE), pH or redox.
- The input of the temperature sensor accepts the Pt100 or Pt1000 with 2-wire or 3-wire connection.

The input B and C if configured as pH can be connected to glass or antimony electrodes.

#### Scales

Input A of the instrument, dedicated to conductivity, can be configured for TDS, ion concentration or resistivity measurements, with the possibility of choosing all possible measurement scales for the various types of sensor used, from 200 nS to 2000 mS.

The measuring unit of the TDS, depending on the scale used, can be in ppb, ppm, ppt.

The measuring unit of ionic concentrations, depending on the scale used, can be in%, ppt, ppm, ppb, g / l, mg / l, ug / l, Bè, custom.

The unit of measurement of resistivity, depending on the scale, can be in Mohm, Kohm, ohm.

The measuring unit of inputs B and C, if configured for ISE electrodes, can be in ppm, ppb, mg / l, g / l, mM, M, custom edited.

The measuring unit of temperature can be selected in ° C or ° F.

Inputs B and C can be configured 0 ÷ 14 pH or -2000 ÷ 2000 mV scales.

In case of measurements out of range, the instrument sends under range or over range messages.

## Temperature compensation

The instrument displays the temperature value and is designed for manual and automatic temperature compensation of the conductivity, pH and ISE measurements.

For absence or malfunction of the temperature sensor the instrument automatically switches to manual compensation, displaying the value of the compensation temperature.

## Relays

The instrument is provided with 4 relays assignable to two set point of three main measuring of the A, B, C inputs.

Depending on the type of application, the relays can be used to control the chemical module for self-calibration of the ISE electrodes.

- Relays 1 and 2 have SPST normally open contacts.
- Relay 3 has SPDT contacts and it can be assigned to the alarm function as well.
- Relay 4 has SPDT contacts and it can be assigned to the autocleaning of the sensors as well.

If the assignment already done is forced to a new assignment, the previous assignment will be considered "not used".

## Analog outputs

The instrument has two analog outputs for PID regulation or to transmit the value of the main measurement and/or temperature, programmable 0-20 mA or 4-20 mA.

The outputs are assignable to the 3 inputs A, B, C, the temperature and the two set points.

The outputs are galvanically isolated, to be directly interfaced with a PLC or data acquisition cards and do not require external power.

If the assignment already done is forced to a new assignment, the previous assignment will be considered "not used"..

## Serial interface

The instrument, equipped with an RS485 interface, is a slave device and can be interrogated by a master (e.g. PLC) with B&C protocol (ascii) or Modbus protocol (RTU, functions 03, 06, 16) to read the measurements and related parameters, to modify the set point, alarm and to manage the cleaning parameters.

In addition to being connected to an RS485 network, the instrument can also be connected to a PC through an RS485 / RS232 or RS485 / USB converter.

The bootloader function allows the firmware update via serial port.

## Configuration

The access the configuration menu is protected by a specific password.

In order to simplify the use it has been proposed separately 4 configuration menu:

- configuration of the system to select the operating mode AUTO / MAN / SIM, the type of temperature sensor, the assignment of the 4 relays to inputs A, B, C and the assignment of 2 analog outputs to the inputs A, B, C, the HOLD / ALARM function of the 2 logic inputs, the baud rate, the identification of B&C protocol and modbus address;
- configuration of the input A to choose the type of measurement: conductivity, TDS, ion concentration or resistivity, the K of cell, the measurement scale, the conversion factors, the measuring units and the filter software.
- configuration of the inputs B to choose the ISE, pH or redox measurement with the relative filter software and the types of regulation, alarm and analogue output on the resources assigned in the system configuration;
- configuration of the input B in terms of pH or redox, type of pH sensor, filter software, types of regulation, alarm and analogue output on the resources assigned in the system configuration;
- If it is configured as ISE, you can choose the preconfigured type of ion (Cl, NO<sub>3</sub>, NH<sub>4</sub>, Ca) or the ion to be edited, the measuring unit, the scale, the filter software, the temperature compensation, the regulation type, the alarms and the use of analog outputs.
- configuration of the input C similar to that described for input B.
- configuration of manual or automatic temperature.

## Setup

The access to the setup menu is protected by a specific password.

In order to simplify the use it has been proposed separately 4 setup menu:

- setup of the system to disable the calibration and set point modification; set the temperature measuring unit and any manual temperature compensation; to enable the 2 logic inputs, to enable the sensor cleaning function and related parameters.
- setup of the input A to choose the manual temperature value, the reference temperature, the temperature coefficient, the parameters of the regulators associated with the main measurement, the LO / Hi alarm values and the delay;
- setup of the input B to choose the manual temperature value, the enabling of the thermocompensation, the temperature coefficient, the point of isopotential ISE, the parameters of the regulators associated with the main measurement, the alarm values LO / Hi and the delay, the parameters for the self-calibration function of the ISE sensors, the degassing and the parameters relating to the standard solutions when using the chemical module for the self-calibration of the ISE sensors.
- setup of the input C similar to that described for input B.

## Set points

The instrument has two independent set points which can be programmed across the whole scale to activate the correspondent relay (contacts SPST) or the PID action.

When using the ON/OFF function, the display shows the status of excitement and delayed actuation.

When using the PID action, the display shows the status of actuation.

Thanks to the specific front panel keys SET1 and SET2, setting the set point value is very simple.

Changing the set point value can be password protected in the setup menu.

For each relay, it is possible to select:

- the ON/OFF or PID action into the configuration menu;
- the type of PID action: FM (pulse frequency modulation) or WM (pulse width modulation) or addressed directly on the analog outputs;
- the function min (LO) or max (HI);
- the parameters of the selected function in the setup menu.

## Alarm

The relay 3 can be assigned to the alarm function in the system configuration.

The alarm condition can be configured to:

- min/max values of the measuring compared to the setting;
- the presence of the contact on the logic input, coming from an external device (if this function is activated);
- overtime of the SET1 and SET2 activation;
- exhaustion of ISE self-calibration solutions.

The operator can select the activated/deactivated status of relay corresponding to the alarm condition and the delay function.

The alarm status and the delayed actuation is visualized on the display.

## Logic inputs

The instrument has two logic inputs to which can be connected a free voltage contact from an external device.

The function of the logic inputs can be enabled or disabled from the setup menu.

The function of these inputs can be on hold/alarm (HOLD/ALARM), whose actions are described in chapter "Technical specification (page 23)", and can be selected in the configuration menu of the system.

The HOLD condition always prevails over the ALARM.

In case of activation of the hold function in the display Messages section will be displayed HOLD status; if a previous alarm condition is present, this indication will be maintained.

## Autoclean

The relay 4 can be assigned to the autoclean function in the system configuration.

Into the setup menu, it is possible to:

- enable or disable the automatic/manual cleaning function;
- set the interval of time between two cleaning cycles;
- set the cleaning time;
- set the holding time after the cleaning.

During the cleaning and holding time the instrument keeps the last value on the analog output, while the set points and the alarm relays remain deactivated.

## Autocalibration

The instrument is able to manage a chemical module which carries out periodic calibration of the ISE sensor.

The one point or two points calibration can be chosen by differentiating the frequency between them as the two point calibration usually requires to be done less frequently. In the appropriate setup menu it is possible to activate the degassing of the measuring cell by setting all the necessary parameters

These functions require the use of relays reducing their usability in process regulation.

- Operation of the chemical module
- The chemical module allows the calibration of the ISE sensor up to two standard solutions.
- It also has a degassing function to eliminate bubbles that have accumulated on the sensor.
- The degassing also starts at the beginning of each calibration cycle in order to eliminate bubbles and reduce the consumption of standard solutions.
- During the filling time of the measuring cell with standard solution  $n \cdot 1$  (delay pump) the countdown time is displayed. At the end of the waiting time the display will show the sensor value.
- It is possible to use two chemical modules to calibrate INPUT B and INPUT C, connecting in "parallel" the commands to operate the 2 calibration points and degassing.
- It is also possible to manage the volume of standard solutions and the ISA to report how much autonomy is left (expressed in days)
- With the frequency of one calibration per day a 1 liter of standard solution has a shelf life of approximately 44 days
- (pump 15 cc / min, calibration time 1.5 min)
- The consumption of the ISA solution is continuous both in measurement and during calibrations.
- Considering a 5 liter ISA solution and the
- 0.1 cc / min the solution lasts about 34 days.

During the calibration time the instrument keeps the last value on the analog output, while the set points and alarm relays remain deactivated.

## Operating mode

The instrument allows 3 operating modes selectable in the system configuration menu.

### Automatic operation (AUTO)

The automatic mode is the normal operation mode of the unit.

The instrument carries out the measurements and consequently activates the set point and alarm relays and the analog outputs

### Measuring operation (MEAS)

The instrument measures the input parameters and keeps the analog outputs active.

The set point and alarm relays are not activated.

The status of the set points is not shown on the main display.

This operating mode is useful for carrying out the initial and ordinary calibration and for observing the reading values in case of manual operation of the system or during the start-up.

### Simulated operation (SIM)

The instrument allows you to simulate the desired values of each individual channel A, B, C, to activate the set point relays, the alarm relay and the assigned analog outputs. The simulated value can be set by the user using the keyboard (see chapter ).

In this operating mode it is not possible to access the calibrations of any parameter.

The type of action, the set point values and the parameters of the analog outputs remain those previously set.

The simulation of the values allows you to test the operation of the devices connected to the relays and the analog outputs without connecting the sensor.

### **Filter software**

A filter software operates on the input signals from the sensors with two time constants selectable in the configuration menu of each individual channel.

The user can separately set the response time relative to signals of small or large variation in order to obtain good reading stability and fast response to the variations in the process.

We suggest to use high values for small variations and low values for large variations of the signal similar as the default values.

### **Universal power supply**

The instrument is equipped with a universal power supply that allows the use of the voltage from 85 to 264 Vac, 50-60 Hz.

### **Option low voltage 9 ÷ 36 Vdc or 12 ÷ 24 Vac**

The installation of this option allows you to use either a DC power supply from 9 to 36 V or an AC voltage from 12 to 24 V, 50-60 Hz.

### **Info menu**

The instrument is provided with an information menu to show:

- p/n and firmware release;
- LCD screen parameters;
- total operating hours.

## 4.2 TECHNICAL DATA

### 4.2.1 GENERAL SPECIFICATIONS

Accuracy	0.2 %
Ripetibility	0.1 %
Non linearity	0.1 %
Alphanumeric display	LCD 128 x 64 pixel
Keyboard	8 keys
Operating temperature	-10 ÷ 60 °C
Humidity	95 % without condensate
Power supply	85 ÷ 2640 Vac +/- 10 % 50/60 Hz 9 ÷ 36 Vcc 12 ÷ 24 Vac (091.428 option)
Power	6 VA max.
Isolation	4000 V between primary and secondary
Immunity performance loss	< 1 % full scale
Terminal blocks	extractable
Weight	1300 g
Dimensions	256 x 230 x 89 mm
Protection	IP 65
EMC/RFI conformity	EN61326
Registered design	002564666-002

## 4.2.2 TECHNICAL SPECIFICATION

In the left column is indicated the number of the display concerning:

- SETUP parameters are indicated by "S xy"
- CONFIGURATION parameters are indicated by "C xy"
- x = paragraph, y = sequential 1..2..3..4..ecc

### System technical specifications

<b>D1.0 3 INPUT SYSTEM (SYSTEM)</b>			Default
D1.1	Input A	Conductivity / TDS / Indirect measure	
D1.2	Input B	ISE / pH / ORP measure	
D1.3	Input C	ISE / pH / ORP measure	
C1.1	Operating Mode	AUTO / MEAS / SIM	AUTO
C1.3	Input A	OFF / CONDUCTIVITY (TDS / INDIRECT)	OFF
C1.4	Input B	OFF / ISE / pH / ORP	OFF
C1.5	Input C	OFF / ISE / pH / ORP	OFF

<b>D2.0 SECONDARY MEASURE (SYSTEM)</b>			Default
C2.1	Input RTD Connection	Pt100 / Pt1000 3 wires	Pt100
S2.1	Measuring unit	°C / °F	°C
	Temperature scale	-10.0 ÷ 110.0 °C 14.0 ÷ 230.0 °F	
	Resolution	0.1 °C / °F	
D2.1	Zero	±5.0 °C ±9.0 °F	0.0 °C 0.0 °F
S2.2	Manual temperature	0.0 ÷ 100.0 °C 32.0 ÷ 212.0 °F	20.0 °C 68.0 °F

<b>RELAYS FUNCTION (SYSTEM)</b>			Default
C3.0	Auto-calibration module (only for ISE input)	OFF / 1 CAL POINT / 2 CAL POINT	OFF
	Relay resource allocation for calibration module	Relay 4 degassing Relay 1 (1° calibration point) Relay 2 (2° calibration point)	
C3.1	Relay 1 function	NOT USED SET 1/2 related to input A/B/C CAL POINT 1	SET 1 IN A
	Contact relay 1	SPST 220 V 5 A resistive	

<b>RELAYS FUNCTION (SYSTEM)</b>			<b>Default</b>
C3.2	Relay 2 function	NOT USED SET 1/2 related to input A/B/C CAL POINT 2	SET 1 IN B
	Contact relay 2	SPST 220 V 5 A resistive	
C3.3	Relay 3 function	NOT USED SET 1/2 related to input A/B/C ALARM	ALARM
	Contact relay 3	SPDT 220 V 5 A resistive	
C3.4	Relay 4 function	NOT USED SET 1/2 related to input A/B/C CLEAN DEGASING	CLEAN
	Contact relay 4	SPDT 220 V 5 A resistive	

<b>ALARM RELAY (SYSTEM)</b>			<b>Default</b>
C4.5	Function if relay 3 = ALARM	ACTIVE / NON ACTIVE	ACTIVE
	Contact of the relay	SPDT 220 V 5 A resistive	

<b>D5.1 ANALOG OUTPUTS (SYSTEM)</b>			<b>Default</b>
C5.1	Analog output 1	NOT USED OUT 1 related to input A/B/C SET 1/2 related to input A/B/C	OUT 1 IN A
C5.2	Analog output 2	NOT USED OUT 2 related to input A/B/C SET 1/2 related to input A/B/C	OUT 2 IN B
	Response time	2.5 seconds for 98 %	
	Isolation	250 Vac	
	R max	600 ohm	

<b>6.0 LOGIC INPUT (2) (SYSTEM)</b>			<b>Default</b>
	<u>HOLD condition</u>	(prevails on ALARM condition)	
	• Analog output	HOLD	
	• Set point	HOLD	
	• Alarm status	Alarm relay OFF	
	• Message on the display	HOLD	
	<u>ALARM condition</u>		
	• Analog output	RUN	
	• Set point	OFF	
	• Alarm status	ON	

6.0	LOGIC INPUT (2) (SYSTEM)		Default
	• Message on the display	ALARM	
S6.1	logic input 1	ON / OFF	OFF
C6.1	Function of the logic input 1	HOLD / ALARM	HOLD
S6.2	Logic input 2	ON / OFF	OFF
C6.2	Function of the logic input 2	HOLD / ALARM	ALARM
	Logic input actuation	free voltage contacts	

D7.0	CLEANING (SYSTEM)		Default
S7.1	Cleaning functions	OFF / AUTO / MANUAL	OFF
	<u>Cleaning parameters</u>		
S7.2	• Repetition time	0.5 ÷ 100.0 hours	24.0 h
S7.3	• Cleaning time	1.0 ÷ 60.0 seconds	15.0 s
S7.4	• Holding time	0.1 ÷ 20.0 minutes	3.0 min
	<u>Cleaning cycle time</u>		
	• Analog output	HOLD	
	• Set point	OFF	
	• Alarm status	OFF	

D8.0	SERIAL INTERFACE (SYSTEM)		Default
	Interface	RS 485 isolated not terminated	
C8.1	Baud rate	2400 / 4800 / 9600 / 19200 baud	9600 baud
	Distance	1000 / 500 / 250 / 125 m	
	Probes in network	32 probes max	
	Protocols		
	B&C protocol	Command A (only reading)	
	Modbus RTU	Functions 03 - 06 - 16	
C8.2	ID B&C protocol	ID = 01 ÷ 99 * last s/n digit, if 0 ID=10	1 ÷ 10 *
C8.3	Modbus address	ID = 01 ÷ 243 * last s/n digit, if 0 ID=10	1 ÷ 10 *

<b>D50.0</b>	<b>SETUP (SYSTEM)</b>		<b>Default</b>
D50.1	Password	000 ÷ 999	0
S1.1	Calibration and set point	ON / OFF	ON
S2.1	Temperature measuring unit	°C / °F	°C
S2.2	Manual temperature	0.0 ÷ 100.0 °C 32.0 ÷ 212.0 °F	20.0 °C
S6.1	Logic input 1	ON / OFF	OFF
S6.2	Logic input 2	ON / OFF	OFF
S7.1	Cleaning function	OFF / AUTOCLEAN / MANUAL	OFF
S7.2	Repetition time	0.5 ÷ 100.0 hours	24.0 h
S7.3	Cleaning time	1.0 ÷ 60.0 seconds	15.0 s
S7.4	Holding time	0.1 ÷ 20.0 minutes	3.0 min
S50.1	Password change	XXX	

<b>D60.0</b>	<b>CONFIGURATION (SYSTEM)</b>		<b>Default</b>
D60.1	Password	000 ÷ 999	0
C1.1	Operating mode	AUTO / MEAS / SIM	AUTO
C1.3	Input A	OFF / CONDUCTIVITY (TDS / INDIRECT)	OFF
C1.4	Input B	OFF / ISE / pH / ORP	OFF
C1.5	Input C	OFF / ISE / pH / ORP	OFF
C2.1	Temperature sensor	Pt100 / Pt1000	Pt100
C3.1	Relay 1 function	NOT USED SET 1/2 related to input A/B/C CAL POINT 1	SET 1 IN A
C3.2	Relay 2 function	NOT USED SET 1/2 related to input A/B/C CAL POINT 2	SET 1 IN B
C3.3	Relay 3 function	NOT USED SET 1/2 related to input A/B/C ALARM	ALARM
C3.4	Relay 4 function	NOT USED SET 1/2 related to input A/B/C CLEAN DEGASING	CLEAN
C4.5	Alarm function if relay 3 = ALARM	ACTIVE / NON ACTIVE	ACTIVE
C5.1	Analog output 1	NOT USED OUT 1 related to input A/B/C SET 1/2 related to input A/B/C	OUT 1 IN A
C5.2	Analog output 2	NOT USED OUT 1 related to input A/B/C SET 1/2 related to input A/B/C	OUT 2 IN B

<b>D60.0 CONFIGURATION (SYSTEM)</b>			Default
C6.1	Logic input 1 function	HOLD / ALARM	HOLD
C6.2	Logic input 2 function	HOLD / ALARM	ALARM
C8.1	Baud rate	2400 / 4800 / 9600 / 19200 baud	9600 baud
C8.2	ID B&C protocol	ID = 01 ÷ 99 * last s/n digit, if 0 ID=10	1 ÷ 10 *
C8.3	Modbus address	ID = 01 ÷ 243 * last s/n digit, if 0 ID=10	1 ÷ 10 *
C60.1	Password change	XXX	

## Input A technical specifications: conductivity measure

D1.1 MAIN MEASURE (INPUT A)							Default
D1.1	Measure	Conductivity / TDS or indirect measure					
D1.1B		Resistivity					
	Input	2 wires cell 4 wires cell (opz. 091.1381)					
C1.1	Measure type	CONDUCTIVITY (TDS / INDIRECT)					COND.
C1.2	K cell	0.01 / 0.1 / 0.5 / 1.0 / 10 cm <sup>-1</sup>					1.0 cm <sup>-1</sup>
C1.3	Scales	1	2	3	4	5	
	K=0.01	200.0 nS / 2000 nS / 20.00 μS / 200.0 μS / 2000 μS					
	K=0.1	2000 nS / 20.00 μS / 200.0 μS / 2000 μS / 20.00 mS					
	K=0.5	10.00 μS / 100.0 μS / 1000 μS / 10.00 mS / 100.0 mS					
	K=1.0	20.00 μS / 200.0 μS / 2000 μS / 20.00 mS / 200.0 mS					2000 μS
	K=10	200.0 μS / 2000 μS / 20.00 mS / 200.0 mS / 2000 mS					
		Scales		Resolution		Reading limits	
		200.0 nS		0.1		-10.0 / 210.0	
		2000 nS		1		-100 / 2100	
		10.00 μS		0.01		-0.50 / 10.50	
		20.00 μS		0.01		-1.00 / 21.00	
		100.0 μS		0.1		-5.0 / 105.0	
		200.0 μS		0.1		-10.0 / 210.0	
		1000 μS		1		-50 / 1050	
		2000 μS		1		-100 / 2100	
		10.00 mS		0.01		-0.50 / 10.50	
		20.00 mS		0.01		-1.00 / 21.00	
		100.0 mS		0.1		-5.0 / 105.0	
		200.0 mS		0.1		-10.0 / 210.0	
		2000 mS		1		-100 / 2100	
D1.11	Zero (conductivity)	±10 % of the scale					0 %
	Calibration	the zero calibration is done automatically on all scales from the lowest one					

D1.1 MAIN MEASURE (INPUT A)					Default
D1.13	Sensitivity (conductivity)	60 ÷ 160 %			100 %
	Calibration type	KCl STANDARD / MEASURE ADJ / SENS ADJ			KCl STD
D1.14	Calibration solution temperature	AUTO/MAN 0 ÷ 100 °C (32 ÷ 212 °F)			AUTO
D1.15	KCl STANDARD calibration TC for calibration	Man/auto with KCl STD solutions KCl solution's TC			
	Solutions standard KCl	0.01 N	0.1 N	1 N	
	Tref 20 °C	1278 µS	11.67 mS	102.1 mS	
	Tref 25 °C	1413 µS	12.88 mS	111.8 mS	
	MEASURE ADJ calibration TC for calibration	Calibration by comparison or with STD solutions similar to process solution TC from configuration			
D1.16	SENS ADJ calibration	Sensitivity direct calibration. Ex. K=1,034 : Sens=103,4 % Ex. K=0.996 : Sens=99,6 %			
	Indirect measure				
C1.3A	TDS scale	Scale EC	TDS scale	Resolution	
		200.0 nS	100.0 ppb	0.1 ppb	
		2000 nS	1000 ppb	1 ppb	
		10.00 µS	5.00 ppm	0.01 ppm	
		20.00 µS	10.00 ppm	0.01 ppm	
		100.0 µS	50.0 ppm	0.1 ppm	
		200.0 µS	100.0 ppm	0.1 ppm	
		1000 µS	500 ppm	1 ppm	
		2000 µS	1000 ppm	1 ppm	1000 ppm
		10.00 mS	5.00 ppt	0.01 ppt	
		20.00 mS	10.00 ppt	0.01 ppt	
		100.0 mS	50.0 ppt	0.1 ppt	
		200.0 mS	100.0 ppt	0.1 ppt	
		2000 mS	1000 ppt	1 ppt	
C1.4A	Conversion factor TDS/EC	0.450 / 1.000 1/S			0.670

<b>D1.1</b>	<b>MAIN MEASURE (INPUT A)</b>		<b>Default</b>
D1.12	TDS calibration	1) Calibration by comparison or TDS solutions with automatic TDS factor correction. 2) Inserimento diretto del fattore TDS in configurazione.	
	Indirect measurement with programmable scale and table		
C1.4B	Measuring unit	% / ppt / ppm / ppb / g/l / mg/l / µg/l / Bè / Custom	%
C1.5B	Custom measuring unit	ABCD (4 characters max)	ABCD
C1.6B	Decimal point	YYYY / YYY.Y / YY.YY / Y.YYY	YYY.Y
C1.7B	Full scale	100 ÷ 9999 digit	100.0 %
C1.8B	EC/indirect measuring table	Editable up to 8 points	2 point
D1.12	Sensitivity (indirect measure)	80 ÷ 120 %	100 %
C1.9	Visualization resistivity measure	ON / OFF	OFF
	Scala EC	R scale	
	200.0 nS	5.00 ÷ 999.99 MOhm	
	2000 nS	0.500 ÷ 99.999 MOhm	
	10.00 µS / 20.00 µS	50.0 ÷ 9999.9 kOhm	
	100.0 µS / 200.0 µS	5.00 ÷ 999.99 kOhm	
	1000 µS / 2000 µS	0.500 ÷ 99.999 kOhm	
	10.00 mS / 20.00 mS	50.0 ÷ 9999.9 Ohm	
	100.0 mS / 200.0 mS	5.00 ÷ 999.99 Ohm	
	2000 mS	0.500 ÷ 99.999 Ohm	
C1.10	RT 90 % large signal	0.4 ÷ 50.0 seconds	2.0 s
C1.11	RT 90 % small signal	0.4 ÷ 50.0 seconds	10.0 s

<b>D2.0</b>	<b>SECONDARY MEASURE (INPUT A)</b>		<b>Default</b>
C2.1	Manual temperature	OFF / ON OFF uses RTD input	OFF
S2.1	Manual temperature (if ON)	0.0 ÷ 100.0 °C 32.0 ÷ 212.0 °F	20.0 °C 68.0 °F
S2.2	Reference temperature	20 °C / 25 °C	20 °C

<b>D2.0 SECONDARY MEASURE (INPUT A)</b>			Default
C2.2	Thermocompensation	COEFFICIENT / TABLE	COEFF.
S2.3	Temperature coefficient	0.0 ÷ 3.50 %/°C / TABLE	2.20 %/°C
	TEMP/EC table	Editable up to 8 points	

<b>3.1 SET POINT 1 (INPUT A)</b>			Default
C3.1	Type of regulation SET1 if related to relay	ON-OFF / PID	ON-OFF
C3.2	Regulation SET1 related to relay and PID	FM / WM	FM
<u>ON-OFF regulation</u>			
D3.11	• Set point (cond.)	0 ÷ full scale	0 µS
S3.1A	• Hysteresis (cond.)	0 ÷ 10 % of full scale	2 µS
D3.11	• Set point (indirect meas.)	0 ÷ full scale	0 ppm
S3.1A	• Hysteresis (indirect meas.)	0 ÷ 10 % of full scale	1 ppm
S3.2A	• Delay	0.0 ÷ 100.0 seconds	0.2 s
C3.3	• Function	LO / HI (Min / Max)	LO
<u>PID regulation</u>			
D3.11	• Set point (cond.)	0 ÷ full scale	0 µS
D3.11	• Set point (indirect meas.)	0 ÷ full scale	0 ppm
S3.1B	• Proportional band	0.0 ÷ 400.0 %	1.0 %
S3.2B	• Integral time	0.0 ÷ 999.9 minutes (0 = disabled)	0.0 min
S3.2B	• Derivative time	0.0 ÷ 999.9 minutes	0.0 min
C3.3	• Function	LO / HI (Min / Max)	LO
<u>FM regulation</u>			
	• PID actuation value	0.0 ÷ 100.0 % PID	
S3.4B	• Pulse frequency	0 ÷ 120 pulses/minute	100 i/min
	• Pulse length	0.1 seconds	
<u>WM regulation</u>			
	• PID actuation value	0.0 ÷ 100.0 % PID	
S3.4B	• Pulse width	0 ÷ 99.9 seconds	20.0 s
	• Minimum pulse length	0.3 seconds	
<u>OUT regulation (analog output)</u>			

<b>3.1 SET POINT 1 (INPUT A)</b>			<b>Default</b>
	• PID actuation value	0.0 ÷ 100.0 % PID	
	• Analog output	4 ÷ 20 mA	
<b>3.2 SET POINT 2 (INPUT A)</b>			<b>Default</b>
C3.4	Type of regulation SET2 if related to relay	ON-OFF / PID	ON-OFF
C3.5	Regulation SET2 related to relay and PID	FM / WM	FM
<u>ON-OFF regulation</u>			
D3.12	• Set point (cond.)	0 ÷ full scale	0 µS
S3.5A	• Hysteresis (cond.)	0 ÷ 10 % of full scale	2 µS
D3.12	• Set point (indirect meas.)	0 ÷ full scale	0 ppm
S3.5A	• Hysteresis (indirect meas.)	0 ÷ 10 % of full scale	1 ppm
S3.6A	• Delay	0.0 ÷ 100.0 seconds	0.2 s
C3.6	• Function	LO / HI (Min / Max)	HI
<u>PID regulation</u>			
D3.12	• Set point (cond.)	0 ÷ full scale	0.00 ppm
D3.12	• Set point (indirect meas.)	0 ÷ full scale	0 ppm
S3.5B	• Proportional band	0.0 ÷ 400.0 %	1.0 %
S3.6B	• Integral time	0.0 ÷ 999.9 minutes	0.0 min
S3.7B	• Derivative time	0.0 ÷ 999.9 minutes (0 = disabled)	0.0 min
C3.6	• Function	LO / HI (Min / Max)	HI
<u>FM regulation</u>			
	• PID actuation value	0.0 ÷ 100.0 % PID	
S3.4B	• Pulse frequency	0 ÷ 120 pulses/minute	100 i/min
	• Pulse length	0.1 seconds	
<u>WM regulation</u>			
	• PID actuation value	0.0 ÷ 100.0 % PID	
S3.4B	• Pulse width	0 ÷ 99.9 seconds	20.0 s
	• Minimum pulse length	0.3 seconds	
<u>OUT regulation (analog output)</u>			
	• PID actuation value	0.0 ÷ 100.0 % PID	

3.2	SET POINT 2 (INPUT A)	Default
	• Analog output	4 ÷ 20 mA

4.0	ALARM (INPUT A)	Default
	<u>Window alarm</u>	
S4.1	• Low value (cond.)	-5 % ÷ 105 % full scale
S4.2	• High value (cond.)	-5 % ÷ 105 % full scale
	• Hysteresis (cond.)	± 0.25 % of full scale
S4.1	• Low value (indirect meas.)	-5 % ÷ 105 % full scale
S4.2	• High value (indirect meas.)	-5 % ÷ 105 % full scale
	• Hysteresis (indirect meas.)	± 0.25 % of full scale
S4.3	• Delay	0.0 ÷ 100.0 seconds
	<u>Alarm on set point</u>	
C4.1	• Alarm on operation SET1	ON / OFF
C4.2	• Operation time of SET1	0 ÷ 60 minutes
C4.3	• Alarm on operation SET2	ON / OFF
C4.4	• Operation time of SET2	0 ÷ 60 minutes

D5.1	ANALOG OUTPUT 1 (INPUT A)	Default
	<u>If not related to SET POINT</u>	
C5.1	Input related to OUT1	µS / mS / ppm / ppt / custom °C / °F
C5.2	Range	0-20 / 4-20 mA
	Under / Over range (0-20)	0.00 / 20.50 mA
	Under / Over range (4-20)	3.50 / 20.50 mA
C5.3	Point 1 (0 mA o 4 mA) (cond.)	0 ÷ full scale
C5.4	Point 2 (20 mA) (cond.)	0 ÷ full scale
C5.3	Point 1 (0 mA o 4 mA) (indirect meas.)	0 ÷ full scale
C5.4	Point 2 (20 mA) (indirect meas.)	0 ÷ full scale
C5.3	Point 1 (0 mA o 4 mA) (°C)	-10.0 ÷ 110.0 °C
C5.4	Point 2 (20 mA) (°C)	-10.0 ÷ 110.0 °C
C5.3	Point 1 (0 mA o 4 mA) (°F)	14.0 ÷ 230.0 °F
C5.4	Point 2 (20 mA) (°F)	14.0 ÷ 230.0 °F

D5.2	ANALOG OUTPUT 2 (INPUT A)	Default
	<u>If not related to SET POINT</u>	

<b>D5.2 ANALOG OUTPUT 2 (INPUT A)</b>			<b>Default</b>
C5.5	Input related to OUT2	ppm / mg/l °C / °F	ppm
C5.6	Range	0-20 / 4-20 mA	0-20 mA
	Under / Over range (0-20)	0.00 / 20.50 mA	
	Under / Over range (4-20)	3.50 / 20.50 mA	
C5.7	Point 1 (0 mA o 4 mA) (ppm)	0 ÷ full scale	0.00 ppm
C5.8	Point 2 (20 mA) (ppm)	0 ÷ full scale	20.00 ppm
C5.7	Point 1 (0 mA o 4 mA) (°C)	-10.0 ÷ 110.0 °C	-10.0 °C
C5.8	Point 2 (20 mA) (°C)	-10.0 ÷ 110.0 °C	110.0 °C
C5.7	Point 1 (0 mA o 4 mA) (°F)	14.0 ÷ 230.0 °F	14.0 °F
C5.8	Point 2 (20 mA) (°F)	14.0 ÷ 230.0 °F	230.0 °F

<b>D50.0 SETUP (INPUT A)</b>			<b>Default</b>
S2.1	Manual temperature (if ON)	0.0 ÷ 100.0 °C 32.0 ÷ 212.0 °F	20.0 °C 68.0 °F
S2.2	Reference temperature	20 °C / 25 °C	20 °C
S2.3	Temperature coefficient	0.0 ÷ 3.50 %/°C / TABLE	2.20 %/°C
S3.1A	Hysteresis SET1 (ON-OFF)	0 ÷ 10 % of FS	2 µS
S3.2A	Delay SET1 (ON-OFF)	0.0 ÷ 100.0 seconds	0.2 s
S3.1B	Proportional band SET1	0.0 ÷ 400.0 %	1.0 %
S3.2B	Integral time SET1	0.0 ÷ 999.9 minutes	0.0 min
S3.3B	Derivative time SET1	0.0 ÷ 999.9 minutes (0=disabled)	0.0 min
S3.4B	Pulse frequency FM SET1	0 ÷ 120 pulses/minute	100 i/min
S3.4B	Pulse width WM SET1	0 ÷ 99.9 seconds	20.0 s
S3.5A	Hysteresis SET2 (ON-OFF)	0 ÷ 10 % of FS	2 µS
S3.6A	Delay SET2 (ON-OFF)	0.0 ÷ 100.0 seconds	0.2 s
S3.5B	Proportional band SET2	0.0 ÷ 400.0 %	1.0 %
S3.6B	Integral time SET2	0.0 ÷ 999.9 minutes	0.0 min
S3.7B	Derivative time SET2	0.0 ÷ 999.9 minutes (0=disabled)	0.0 min
S3.8B	Pulse frequency FM SET2	0 ÷ 120 pulses/minute	100 i/min
S3.8B	Pulse width WM SET2	0 ÷ 99.9 seconds	20.0 s
S4.1	Alarm LO (low value)	-5 % ÷ 105 % full scale	0 µS
S4.2	Alarm HI (high)	-5 % ÷ 105 % full scale	2000 µS
S4.3	Alarm delay	0.0 ÷ 100.0 seconds	1.0 s

<b>D60.0 CONFIGURATION (INPUT A)</b>			<b>Default</b>
C1.1	Type of measure	CONDUCTIVITY / TDS / INDIRECT	COND.

D60.0 CONFIGURATION (INPUT A)		Default
C1.2	K cell	0.01 / 0.1 / 0.5 / 1.0 / 10 cm <sup>-1</sup>
C1.3	EC scale	
	K=0.01	200.0 nS / 2000 nS / 20.00 μS / 200.0 μS / 2000 μS
	K=0.1	2000 nS / 20.00 μS / 200.0 μS / 2000 μS / 20.00 mS
	K=0.5	10.00 μS / 100.0 μS / 1000 μS / 10.00 mS / 100.0 mS
	K=1.0	20.00 μS / 200.0 μS / 2000 μS / 20.00 mS / 200.0 mS
	K=10	200.0 μS / 2000 μS / 20.00 mS / 200.0 mS / 2000 mS
C1.3A	TDS scale	Depending on the cell K
C1.4A	TDS/EC conversion factor	0.450 ÷ 1.000 1/S
C1.4B	Measuring unit (indirect meas.)	% / ppt / ppm / ppb / g/l / mg/l / μg/l / Bè / Custom
C1.5B	Custom measuring unit	ABCD (4 characters max)
C1.6B	Decimal point (indirect meas.)	YYYY / YYY.Y / YY.YY / Y.YYY
C1.7B	Full scale (indirect meas.)	100 ÷ 9999 digit
C1.8B	EC/indirect measuring table	Editable up to 8 points
C1.9	Resistivity measure	ON / OFF
C1.10	RT Large Signal	0.4 ÷ 50.0 seconds
C1.11	RT Small Signal	0.4 ÷ 50.0 seconds
C2.1	Manual temperature	OFF / ON OFF uses RTD input
C2.2	Thermocompensation	COEFFICIENT / TABLE
C3.1	SET 1 regulation	ON-OFF / PID
C3.2	SET 1 actuation (PID only)	FM / WM
C3.3	SET 1 function	LO / HI (Min / Max)
C3.4	SET 2 regulation	ON-OFF / PID
C3.5	SET 2 actuation (PID only)	FM / WM
C3.6	SET 2 function	LO / HI (Min / Max)
C4.1	Alarm related to SET1 operation time	ON / OFF
C4.2	SET1 operation time	0 ÷ 60 minutes
C4.3	Alarm related to SET2 operation time	ON / OFF
C4.4	SET2 operation time	0 ÷ 60 minutes

<b>D60.0 CONFIGURATION (INPUT A)</b>			<b>Default</b>
C5.1	Measure on analog output 1	$\mu\text{S}$ / $\text{mS}$ / ppm / ppt / custom $^{\circ}\text{C}$ / $^{\circ}\text{F}$	$\mu\text{S}$
C5.2	Analog output 1 range	0-20 / 4-20 mA	0-20 mA
C5.3	Point 1 analog output 1	0 $\div$ full scale	0 $\mu\text{S}$
C5.4	Point 2 analog output 1	0 $\div$ full scale	2000 $\mu\text{S}$
C5.5	Measure on analog output 2	$\mu\text{S}$ / $\text{mS}$ / ppm / ppt / custom $^{\circ}\text{C}$ / $^{\circ}\text{F}$	$\mu\text{S}$
C5.6	Analog output 2 range	0-20 / 4-20 mA	0-20 mA
C5.7	Point 1 analog output 2	0 $\div$ full scale	0 $\mu\text{S}$
C5.8	Point 2 analog output 2	0 $\div$ full scale	2000 $\mu\text{S}$

### Input B technical specifications: pH/ORP measure

<b>D1.2 MAIN MEASURE (INPUT B)</b>			<b>Default</b>
C1.1	Type of measure	pH / ORP	pH
C1.2	Type of pH sensor Type of ORP sensor	GLASS / ANTIMONY / EXT. 4-20 mA ORP	GLASS
	GLASS pH electrode		
	• Slope	59.16 mV / pH at 25 $^{\circ}\text{C}$	
	• Asymmetric potential 7.00 pH	0.0 mV	
D1.21	• Zero	$\pm 2.00$ pH	0.00 pH
D1.22	• Sensitivity	80 % $\div$ 110 %	100 %
	ANTIMONY pH electrode		
	• Slope	50.00 mV / pH at 25 $^{\circ}\text{C}$	
	• Asymmetric potential 7.00 pH	-325 mV	
D1.21	• Zero	$\pm 2.00$ pH	0.00 pH
D1.22	• Sensitivity	70 % $\div$ 140 %	100 %
	Input for external transmitter 0 $\div$ 14 pH		
	• Zero	400 $\div$ 2000 mV transmitter 4-20 mA + resistance (shunt) 100 ohm 0.1 % on input	
	• Sensitivity	Set the transmitter	
	• Sensitivity	Set the transmitter	
	ORP electrode		

D1.2	MAIN MEASURE (INPUT B)		Default
D1.21	• Zero	$\pm 100$ mV	0 mV
D1.22	• Sensitivity	80 % ÷ 110 %	100 %
	pH scale	0.00 ÷ 14.00 pH	
	Resolution	0.01 pH	
	Under range	-1.00 pH	
	Over range	15.00 pH	
	ORP scale	-2000 ÷ 2000 mV	
	Resolution	1 mV	
	Under range	-2100 mV	
	Over range	2100 mV	
	Filter software		
C1.3	Response time at 90 % large signal	0.4 ÷ 50.0 seconds	2.0 s
C1.4	Response time at 90 % small signal	0.4 ÷ 50.0 seconds	10.0 s

3.1	SET POINT 1 (INPUT B)		Default
C3.1	Type of regulation SET1 if related to relay	ON-OFF / PID	ON-OFF
C3.2	Regulation SET1 related to relay and PID	FM / WM	FM
	<u>ON-OFF regulation</u>		
D3.21	• Set point (pH)	0.00 ÷ 14.00 pH	0.00 pH
D3.21	• Set point (ORP)	-2000 ÷ 2000 mV	0 mV
S3.1A	• Hysteresis (pH)	0.00 ÷ 1.40 pH	0.02 pH
S3.1A	• Hysteresis (mV)	0 ÷ 200 mV	1 mV
S3.2A	• Delay	0.0 ÷ 100.0 seconds	0.2 s
C3.3	• Function	LO / HI (Min / Max)	LO
	<u>PID regulation</u>		
D3.21	• Set point (pH)	0.00 ÷ 14.00 pH	0.00 pH
D3.21	• Set point (ORP)	-2000 ÷ 2000 mV	0 mV
S3.1B	• Proportional band	0.0 ÷ 400.0 %	1.0 %
S3.2B	• Integral time	0.0 ÷ 999.9 minutes	0.0 min

3.1	SET POINT 1 (INPUT B)	Default	
S3.2B	• Derivative time	0.0 ÷ 999.9 minutes (0=disabl.)	0.0 min
C3.3	• Function	LO / HI (Min / Max)	LO
<u>FM regulation</u>			
	• PID actuation value	0.0 ÷ 100.0 % PID	
S3.4B	• Pulse frequency	0 ÷ 120 pulses/minute	100 i/min
	• Pulse length	0.1 seconds	
<u>WM regulation</u>			
	• PID actuation value	0.0 ÷ 100.0 % PID	
S3.4B	• Pulse width	0 ÷ 99.9 seconds	20.0 s
	• Minimum pulse length	0.3 seconds	
<u>OUT regulation (analog output)</u>			
	• PID actuation value	0.0 ÷ 100.0 % PID	
	• Analog output	4 ÷ 20 mA	

3.1	SET POINT 2 (INPUT B)	Default	
C3.1	Type of regulation SET2 if related to relay	ON-OFF / PID	ON-OFF
C3.2	Regulation SET2 related to relay and PID	FM / WM	FM
<u>ON-OFF regulation</u>			
D3.22	• Set point (pH)	0.00 ÷ 14.00 pH	0.00 pH
D3.22	• Set point (ORP)	-2000 ÷ 2000 mV	0 mV
S3.1A	• Hysteresis (pH)	0.00 ÷ 1.40 pH	0.02 pH
S3.1A	• Hysteresis (mV)	0 ÷ 200 mV	1 mV
S3.2A	• Delay	0.0 ÷ 100.0 seconds	0.2 s
C3.3	• Function	LO / HI (Min / Max)	HI
<u>PID regulation</u>			
D3.22	• Set point (pH)	0.00 ÷ 14.00 pH	0.00 pH
D3.22	• Set point (ORP)	-2000 ÷ 2000 mV	0 mV
S3.1B	• Proportional band	0.0 ÷ 400.0 %	1.0 %
S3.2B	• Integral time	0.0 ÷ 999.9 minutes	0.0 min
S3.2B	• Derivative time	0.0 ÷ 999.9 minutes (0 = disabled)	0.0 min

3.1	SET POINT 2 (INPUT B)	Default
C3.3	• Function	LO / HI (Min / Max)
		HI
	<u>FM regulation</u>	
	• PID actuation value	0.0 ÷ 100.0 % PID
S3.4B	• Pulse frequency	0 ÷ 120 pulses/minute
	• Pulse length	0.1 seconds
	<u>WM regulation</u>	
	• PID actuation value	0.0 ÷ 100.0 % PID
S3.4B	• Pulse width	0 ÷ 99.9 seconds
	• Minimum pulse length	0.3 seconds
	<u>OUT regulation (analog output)</u>	
	• PID actuation value	0.0 ÷ 100.0 % PID
	• Analog output	4 ÷ 20 mA

4.0	ALARM (INPUT B)	Default
	<u>Window alarm</u>	
S4.1	• Low value (pH)	0.00 ÷ 14.00 pH
S4.2	• High value (pH)	0.00 ÷ 14.00 pH
	• Hysteresis (pH)	± 0.2 pH
S4.1	• Low value (ORP)	-2000 ÷ 2000 mV
S4.2	• High value (ORP)	-2000 ÷ 2000 mV
	• Hysteresis (ORP)	± 1 mV
S4.3	• Delay	0.0 ÷ 100.0 seconds
	<u>Alarm on set point</u>	
C4.1	• Alarm on operation SET1	ON / OFF
C4.2	• Operation time of SET1	0 ÷ 60 minutes
C4.3	• Alarm on operation SET2	ON / OFF
C4.4	• Operation time of SET2	0 ÷ 60 minutes

D5.1	ANALOG OUTPUT 1 (INPUT B)	Default
	<u>If not related to SET POINT</u>	
C5.1	Input related to OUT1	pH   mV / °C   °F
C5.2	Range	0-20 / 4-20 mA
	Under / Over range (0-20)	0.00 / 20.50 mA

<b>D5.1</b>	<b>ANALOG OUTPUT 1 (INPUT B)</b>		<b>Default</b>
	Under / Over range (4-20)	3.50 / 20.50 mA	
C5.3	Point 1 (0 mA o 4 mA) (pH)	0.00 ÷ 14.00 pH	0.00 pH
C5.4	Point 2 (20 mA) (pH)	0.00 ÷ 14.00 pH	14.00 pH
C5.3	Point 1 (0 mA o 4 mA) (ORP)	-2000 ÷ 2000 mV	-2000 mV
C5.4	Point 2 (20 mA) (ORP)	-2000 ÷ 2000 mV	2000 mV
C5.3	Point 1 (0 mA o 4 mA) (°C)	-10.0 ÷ 110.0 °C	-10.0 °C
C5.4	Point 2 (20 mA) (°C)	-10.0 ÷ 110.0 °C	110.0 °C
C5.3	Point 1 (0 mA o 4 mA) (°F)	14.0 ÷ 230.0 °F	14.0 °F
C5.4	Point 2 (20 mA) (°F)	14.0 ÷ 230.0 °F	230.0 °F

<b>D5.2</b>	<b>ANALOG OUTPUT 2 (INPUT B)</b>		<b>Default</b>
	<u>If not related to SET POINT</u>		
C5.5	Input related to OUT2	pH   mV / °C   °F	pH
C5.6	Range	0-20 / 4-20 mA	0-20 mA
	Under / Over range (0-20)	0.00 / 20.50 mA	
	Under / Over range (4-20)	3.50 / 20.50 mA	
C5.7	Point 1 (0 mA o 4 mA) (pH)	0.00 ÷ 14.00 pH	0.00 pH
C5.8	Point 2 (20 mA) (pH)	0.00 ÷ 14.00 pH	14.00 pH
C5.7	Point 1 (0 mA o 4 mA) (ORP)	-2000 ÷ 2000 mV	-2000 mV
C5.8	Point 2 (20 mA) (ORP)	-2000 ÷ 2000 mV	2000 mV
C5.7	Point 1 (0 mA o 4 mA) (°C)	-10.0 ÷ 110.0 °C	-10.0 °C
C5.8	Point 2 (20 mA) (°C)	-10.0 ÷ 110.0 °C	110.0 °C
C5.7	Point 1 (0 mA o 4 mA) (°F)	14.0 ÷ 230.0 °F	14.0 °F
C5.8	Point 2 (20 mA) (°F)	14.0 ÷ 230.0 °F	230.0 °F

<b>D50.0</b>	<b>SETUP (INPUT B)</b>		<b>Default</b>
S3.1A	Hysteresis SET1 (ON-OFF)	0.00 ÷ 1.40 pH	0.02 pH
S3.2A	Delay SET1 (ON-OFF)	0.0 ÷ 100.0 seconds	0.2 s
S3.1B	Proportional band SET1	0.0 ÷ 400.0 %	1.0 %
S3.2B	Integral time SET1	0.0 ÷ 999.9 minutes	0.0 min
S3.3B	Derivative time SET1	0.0 ÷ 999.9 minutes (0 = disabled)	0.0 min
S3.4B	Pulse frequency FM SET1	0 ÷ 120 pulses/minute	100 i/min
S3.4B	Pulse width WM SET1	0 ÷ 99.9 seconds	20.0 s
S3.5A	Hysteresis SET2 (ON-OFF)	0.00 ÷ 1.40 pH	0.02 pH
S3.6A	Delay SET2 (ON-OFF)	0.0 ÷ 100.0 seconds	0.2 s
S3.5B	Proportional band SET2	0.0 ÷ 400.0 %	1.0 %
S3.6B	Integral time SET2	0.0 ÷ 999.9 minutes	0.0 min

<b>D50.0 SETUP (INPUT B)</b>			Default
S3.7B	Derivative time SET2	0.0 ÷ 999.9 minutes (0 = disabled)	0.0 min
S3.8B	Pulse frequency FM SET2	0 ÷ 120 pulses/minute	100 i/min
S3.8B	Pulse width WM SET2	0 ÷ 99.9 seconds	20.0 s
S4.1	Alarm LO (low value)	0.00 ÷ 14.0 pH	0.00 pH
S4.2	Alarm HI (high value)	0.00 ÷ 14.0 pH	14.00 pH
S4.3	Alarm delay	0.0 ÷ 100.0 seconds	1.0 s

<b>D60.0 CONFIGURATION (INPUT B)</b>			Default
C1.1	Type of measure	pH / ORP	pH
C1.2	Type of pH sensor	GLASS / ANTIMONY / EXT. 4-20 mA	GLASS
C1.3	RT Large Signal	0.4 ÷ 50.0 seconds	2.0 s
C1.4	RT Small Signal	0.4 ÷ 50.0 seconds	10.0 s
C3.1	SET1 regulation	ON-OFF / PID	ON-OFF
C3.2	SET1 regulation related to (PID only)	FM / WM / OUT1 FM/WM on relay 1	FM
C3.3	SET1 function	LO / HI (Min / Max)	LO
C3.4	SET2 regulation	ON-OFF / PID	OFF
C3.5	SET2 regulation related to (PID only)	FM / WM / OUT2 FM/WM on relay 2	FM
C3.6	SET2 function	LO / HI (Min / Max)	HI
C4.1	Alarm related to SET1 operation time	ON / OFF	OFF
C4.2	SET1 operation time	0 ÷ 60 minutes	60 min
C4.3	Alarm related to SET2 operation time	ON / OFF	OFF
C4.4	SET2 operation time	0 ÷ 60 minutes	60 min
C5.1	Input related to the analog output 1	pH / mV °C / °F	pH
C5.2	Analog output 1 range	0-20 / 4-20 mA	0-20 mA
C5.3	Point 1 analog output 1	0.00 ÷ 14.00 pH	0.00 pH
C5.4	Point 2 analog output 1	0.00 ÷ 14.00 pH	14.00 pH
C5.5	Input related to the analog output 2	pH / mV °C / °F	pH
C5.6	Analog output 2 range	0-20 / 4-20 mA	0-20 mA
C5.7	Point 1 analog output 2	0.00 ÷ 14.00 pH	0.00 pH
C5.8	Point 2 analog output 2	0.00 ÷ 14.00 pH	14.00 pH

**Input C technical specifications: pH/ORP measure**

<b>D1.3</b>	<b>MAIN MEASURE (INPUT C)</b>		<b>Default</b>
C1.1	Type of measure	pH / ORP	ORP
C1.2	Type of pH sensor Type of ORP sensor	GLASS / ANTIMONY / EXT. 4-20 mA ORP	GLASS
	GLASS pH electrode		
	• Slope	59.16 mV / pH at 25 °C	
	• Asymmetric potential 7.00 pH	0.0 mV	
D1.31	• Zero	± 2.00 pH	0.00 pH
D1.32	• Sensitivity	80 % ÷ 110 %	100 %
	ANTIMONY pH electrode		
	• Slope	50.00 mV / pH at 25 °C	
	• Asymmetric potential 7.00 pH	-325 mV	
D1.31	• Zero	± 2.00 pH	0.00 pH
D1.32	• Sensitivity	70 % ÷ 140 %	100 %
	Input for external transmitter 0 ÷ 14 pH		
		400 ÷ 2000 mV transmitter 4-20 mA + resistance (shunt) 100 ohm 0.1 % on input	
	• Zero	Set the transmitter	
	• Sensitivity	Set the transmitter	
	ORP electrode		
D1.31	• Zero	± 100 mV	0 mV
D1.32	• Sensitivity	80 % ÷ 110 %	100 %
	pH scale		
		0.00 ÷ 14.00 pH	
	Resolution	0.01 pH	
	Under range	-1.00 pH	
	Over range	15.00 pH	
	ORP scale		
		-2000 ÷ 2000 mV	
	Resolution	1 mV	
	Under range	-2100 mV	
	Over range	2100 mV	

D1.3	MAIN MEASURE (INPUT C)	Default
	Filter software	
C1.3	Response time at 90 % large signal	0.4 ÷ 50.0 seconds
C1.4	Response time at 90 % small signal	0.4 ÷ 50.0 seconds

3.1	SET POINT 1 (INPUT C)	Default
C3.1	Type of regulation SET1 if related to relay	ON-OFF / PID
C3.2	Regulation SET1 related to relay and PID	FM / WM
	<u>ON-OFF regulation</u>	
D3.31	• Set point (pH)	0.00 ÷ 14.00 pH
D3.31	• Set point (ORP)	-2000 ÷ 2000 mV
S3.1A	• Hysteresis (pH)	0.00 ÷ 1.40 pH
S3.1A	• Hysteresis (mV)	0 ÷ 200 mV
S3.2A	• Delay	0.0 ÷ 100.0 seconds
C3.3	• Function	LO / HI (Min / Max)
	<u>PID regulation</u>	
D3.31	• Set point (pH)	0.00 ÷ 14.00 pH
D3.31	• Set point (ORP)	-2000 ÷ 2000 mV
S3.1B	• Proportional band	0.0 ÷ 400.0 %
S3.2B	• Integral time	0.0 ÷ 999.9 minutes
S3.2B	• Derivative time	0.0 ÷ 999.9 minutes (0=disabl.)
C3.3	• Function	LO / HI (Min / Max)
	<u>FM regulation</u>	
	• PID actuation value	0.0 ÷ 100.0 % PID
S3.4B	• Pulse frequency	0 ÷ 120 pulses/minute
	• Pulse length	0.1 seconds
	<u>WM regulation</u>	
	• PID actuation value	0.0 ÷ 100.0 % PID
S3.4B	• Pulse width	0 ÷ 99.9 seconds
	• Minimum pulse length	0.3 seconds

3.1	SET POINT 1 (INPUT C)	Default
	<u>OUT regulation (analog output)</u>	
	• PID actuation value	0.0 ÷ 100.0 % PID
	• Analog output	4 ÷ 20 mA

3.1	SET POINT 2 (INPUT C)	Default
C3.1	Type of regulation SET2 if related to relay	ON-OFF / PID
C3.2	Regulation SET2 related to relay and PID	FM / WM
	<u>ON-OFF regulation</u>	
D3.32	• Set point (pH)	0.00 ÷ 14.00 pH
D3.32	• Set point (ORP)	-2000 ÷ 2000 mV
S3.1A	• Hysteresis (pH)	0.00 ÷ 1.40 pH
S3.1A	• Hysteresis (mV)	0 ÷ 200 mV
S3.2A	• Delay	0.0 ÷ 100.0 seconds
C3.3	• Function	LO / HI (Min / Max)
	<u>Regulation PID</u>	
D3.32	• Set point (pH)	0.00 ÷ 14.00 pH
D3.32	• Set point (ORP)	-2000 ÷ 2000 mV
S3.1B	• Proportional band	0.0 ÷ 400.0 %
S3.2B	• Integral time	0.0 ÷ 999.9 minutes
S3.2B	• Derivative time	0.0 ÷ 999.9 minutes (0 = disabled)
C3.3	• Function	LO / HI (Min / Max)
	<u>FM regulation</u>	
	• PID actuation value	0.0 ÷ 100.0 % PID
S3.4B	• Pulse frequency	0 ÷ 120 pulses/minute
	• Pulse length	0.1 seconds
	<u>WM regulation</u>	
	• PID actuation value	0.0 ÷ 100.0 % PID
S3.4B	• Pulse width	0 ÷ 99.9 seconds
	• Minimum pulse length	0.3 seconds
	<u>OUT regulation (analog output)</u>	

3.1	SET POINT 2 (INPUT C)	Default
	• PID actuation value	0.0 ÷ 100.0 % PID
	• Analog output	4 ÷ 20 mA

4.0	ALARM (INPUT C)	Default
	<u>Window alarm</u>	
S4.1	• Low value (pH)	0.00 ÷ 14.00 pH
S4.2	• High value (pH)	0.00 ÷ 14.00 pH
	• Hysteresis (pH)	± 0.2 pH
S4.1	• Low value (ORP)	-2000 ÷ 2000 mV
S4.2	• High value (ORP)	-2000 ÷ 2000 mV
	• Hysteresis (ORP)	± 1 mV
S4.3	• Delay	0.0 ÷ 100.0 seconds
	<u>Alarm on set point</u>	
C4.1	• Alarm on operation SET1	ON / OFF
C4.2	• Operation time of SET1	0 ÷ 60 minutes
C4.3	• Alarm on operation SET2	ON / OFF
C4.4	• Operation time of SET2	0 ÷ 60 minutes

D5.1	ANALOG OUTPUT 1 (INPUT C)	Default
	<u>If not related to SET POINT</u>	
C5.1	Input related to OUT1	pH   mV / °C   °F
C5.2	Range	0-20 / 4-20 mA
	Under / Over range (0-20)	0.00 / 20.50 mA
	Under / Over range (4-20)	3.50 / 20.50 mA
C5.3	Point 1 (0 mA o 4 mA) (pH)	0.00 ÷ 14.00 pH
C5.4	Point 2 (20 mA) (pH)	0.00 ÷ 14.00 pH
C5.3	Point 1 (0 mA o 4 mA) (ORP)	-2000 ÷ 2000 mV
C5.4	Point 2 (20 mA) (ORP)	-2000 ÷ 2000 mV
C5.3	Point 1 (0 mA o 4 mA) (°C)	-10.0 ÷ 110.0 °C
C5.4	Point 2 (20 mA) (°C)	-10.0 ÷ 110.0 °C
C5.3	Point 1 (0 mA o 4 mA) (°F)	14.0 ÷ 230.0 °F
C5.4	Point 2 (20 mA) (°F)	14.0 ÷ 230.0 °F

D5.2	ANALOG OUTPUT 2 (INPUT C)	Default
	<u>If not related to SET POINT</u>	
C5.5	Input related to OUT2	pH   mV / °C   °F

<b>D5.2 ANALOG OUTPUT 2 (INPUT C)</b>			Default
C5.6	Range	0-20 / 4-20 mA	0-20 mA
	Under / Over range (0-20)	0.00 / 20.50 mA	
	Under / Over range (4-20)	3.50 / 20.50 mA	
C5.7	Point 1 (0 mA o 4 mA) (pH)	0.00 ÷ 14.00 pH	0.00 pH
C5.8	Point 2 (20 mA) (pH)	0.00 ÷ 14.00 pH	14.00 pH
C5.7	Point 1 (0 mA o 4 mA) (ORP)	-2000 ÷ 2000 mV	-2000 mV
C5.8	Point 2 (20 mA) (ORP)	-2000 ÷ 2000 mV	2000 mV
C5.7	Point 1 (0 mA o 4 mA) (°C)	-10.0 ÷ 110.0 °C	-10.0 °C
C5.8	Point 2 (20 mA) (°C)	-10.0 ÷ 110.0 °C	110.0 °C
C5.7	Point 1 (0 mA o 4 mA) (°F)	14.0 ÷ 230.0 °F	14.0 °F
C5.8	Point 2 (20 mA) (°F)	14.0 ÷ 230.0 °F	230.0 °F

<b>D50.0 SETUP (INPUT C)</b>			Default
S3.1A	Hysteresis SET1 (ON-OFF)	0 ÷ 200 mV	1 mV
S3.2A	Delay SET1 (ON-OFF)	0.0 ÷ 100.0 seconds	0.2 s
S3.1B	Proportional band SET1	0.0 ÷ 400.0 %	1.0 %
S3.2B	Integral time SET1	0.0 ÷ 999.9 minutes	0.0 min
S3.3B	Derivative time SET1	0.0 ÷ 999.9 minutes (0 = disabled)	0.0 min
S3.4B	Pulse frequency FM SET1	0 ÷ 120 pulses/minute	100 i/min
S3.4B	Pulse width WM SET1	0 ÷ 99.9 seconds	20.0 s
S3.5A	Hysteresis SET2 (ON-OFF)	0 ÷ 200 mV	1 mV
S3.6A	Delay SET2 (ON-OFF)	0.0 ÷ 100.0 seconds	0.2 s
S3.5B	Proportional band SET2	0.0 ÷ 400.0 %	1.0 %
S3.6B	Integral time SET2	0.0 ÷ 999.9 minutes	0.0 min
S3.7B	Derivative time SET2	0.0 ÷ 999.9 minutes (0 = disabled)	0.0 min
S3.8B	Pulse frequency FM SET2	0 ÷ 120 pulses/minute	100 i/min
S3.8B	Pulse width WM SET2	0 ÷ 99.9 seconds	20.0 s
S4.1	Alarm LO (low value)	-2000 ÷ 2000 mV	-2000 mV
S4.2	Alarm HI (high value)	-2000 ÷ 2000 mV	2000 mV
S4.3	Alarm delay	0.0 ÷ 100.0 seconds	1.0 s

<b>D60.0 CONFIGURATION (INPUT C)</b>			Default
C1.1	Type of measure	pH / ORP	ORP
C1.2	Type of pH sensor	GLASS / ANTIMONY / EXT. 4-20 mA	GLASS
C1.3	RT Large Signal	0.4 ÷ 50.0 seconds	2.0 s
C1.4	RT Small Signal	0.4 ÷ 50.0 seconds	10.0 s
C3.1	SET1 regulation	ON-OFF / PID	ON-OFF

<b>D60.0 CONFIGURATION (INPUT C)</b>			Default
C3.2	SET1 regulation related to (PID only)	FM / WM	FM
C3.3	SET1 function	LO / HI (Min / Max)	LO
C3.4	SET2 regulation	ON-OFF / PID	OFF
C3.5	SET2 regulation related to (PID only)	FM / WM	FM
C3.6	SET2 function	LO / HI (Min / Max)	HI
C4.1	Alarm related to SET1 operation time	ON / OFF	OFF
C4.2	SET1 operation time	0 ÷ 60 minutes	60 min
C4.3	Alarm related to SET2 operation time	ON / OFF	OFF
C4.4	SET2 operation time	0 ÷ 60 minutes	60 min
C5.1	Input related to the analog output 1	pH / mV °C / °F	mV
C5.2	Analog output 1 range	0-20 / 4-20 mA	0-20 mA
C5.3	Point 1 analog output 1	-2000 ÷ 2000 mV	-2000 mV
C5.4	Point 2 analog output 1	-2000 ÷ 2000 mV	2000 mV
C5.5	Input related to the analog output 2	pH / mV °C / °F	mV
C5.6	Analog output 2 range	0-20 / 4-20 mA	0-20 mA
C5.7	Point 1 analog output 2	-2000 ÷ 2000 mV	-2000 mV
C5.8	Point 2 analog output 2	-2000 ÷ 2000 mV	2000 mV

<b>70.0 INFO MENU</b>			Default
I1.0	Release code	CL6587.103 R1.1X	
I2.0	LCD brightness	(0 ÷ 30)	20
I3.0	LCD contrast	(0 ÷ 30)	12
I4.0	LCD mode	NORMAL / REVERSE	NORMAL
I5.0	Hours of operation time	xxxxxx hours	

## 5 INSTALLATION

### 5.1 PACKING LIST

The package contains:

- N° 1 unit with serial number label;
- N° 1 instruction manual.

### 5.2 PACKING AND UNPACKING

- 1 Open the carton box and keep it.
  - 2 Remove the instrument for the carton box.
  - 3 Remove the plastic protection from the instrument.
- If repackaging do the reverse.

### 5.3 STORAGE AND TRANSPORT

For prolonged storage, keep the product in dry places.  
In case of transportation, pack the product in a carton box.

### 5.4 INSTALLATION

The instrument can be installed in proximity of the sensor or in a remote area.  
The installation must be performed on a rigid surface, in a protected position from shock and corrosive fumes.

Accessories for alternate mounting are available on request (see Fig. 3 and Fig. 4 of chapter "Dimensions and installation (page 98)").

#### 5.4.1 WALL MOUNTING INSTRUCTIONS

The instrument requires 3 screws and fixing accessories suitable for the wall material for mounting (see Fig. 2):

- a screw in the top center of the instrument to hang it;
- two fixing screws at the bottom of the instrument.

Open the front cover to fix these two screws.

The diameter for the top screw head is 8.5 mm.

The diameter for the bottom screws is 4.7 mm.

#### Mounting without a drilling template

- 1 Fix the central screw on the wall, ensuring a distance of 6 mm between the screw head and the wall.

- 2 Remove the front cover of the instrument.
- 3 Hang the instrument on the central screw (attention to the edge of the screw head, if excessive it can remove the instrument's inner seal).
- 4 Mark on the wall the position of the bottom holes.
- 5 Remove the instrument and drill the two holes.
- 6 Hang the instrument again.
- 7 Fasten the two bottom screws in the holes.
- 8 Make the electrical connections and close the cover.

### Mounting with a drilling template

- 1 Prepare a drilling template according to the measurements shown in Fig. 1 of chapter "Dimensions and installation (page 98)".
- 2 Make the 3 holes required.
- 3 Perform steps 1-2-3-7-8 of "Mounting without a drilling template".

## 5.5 INSTALLATION OF THE SENSORS

Follow the specific instructions for flow, in-pipe, or immersion sensor installations.

In particular, it is necessary to check the compatibility of the holders material and the sensors with the temperature, pressure and chemical composition of the sample.

Contact our sales department to choose the most suitable sensor for your specific application.

Protect the cable of the sensor from rain or corrosive agents, for example through a sheath.

The interruption of the cable can cause interferences, therefore is not recommended.

In case of cable extension use high isolation IP 65 junction box (for example the accessory SZ 740).

Keep the cable of the sensor away from the power cables.

## 5.6 ELECTRICAL INSTALLATION

For all the electrical connections refer to the label on the instruments, also shown and described in the chapter "Installation drawings (page 97)".

The connections to the instrument are made using removable terminal blocks located inside the device, accessible via 6 cable glands (2 x PG11, 2 x PG9, 2 x PG7).

 *The cable glands are provided with a closure that guarantees the IP65 sealing; unscrew the ring and remove it only for the cable glands actually used.*

*Use the appropriate cable diameter to ensure the IP65 sealing.*

The power connections are on two terminal blocks (one for a power supply and one for connection to the relays).

The power connections of the input signals are on a 12-position terminal block.

The connections of the analog and logic input are on a 6-position terminal block. The RS485 connections are on a 4-position terminal block.

### 5.6.1 CONNECTING TO THE MAINS

- Connect the ground to the terminal 3
- Connect the mains to the terminals 1-2 marked L-N.

-  The device is very sensitive and absorbs very little power. Use the following precautions to avoid irreversible damage to the electronic circuits.
- Power the device between phase and neutral. Avoid the use of auto-transformers.
  - Avoid power taken from nodes with strong inductive loads that may produce noise or damage to the internal circuits.
  - In the case of installations with the presence of inverter, check that they are properly installed and not induce noise on the network, on the ground or on the signals.
  - Install a switch in the control cabinet for the power of the instrument. This switch can be "specific" or "general" for all electronic equipment installed.
  - Install in the control cabinet protection fuses for power supply.
  - Install the power cables away from the signal cables.
  - Check the voltage supply before turning on the power.

-  It should be remembered that the electronic instruments may be subject to accidental failures. Take the necessary precautions to avoid any damage caused by their dysfunction.

### 5.6.2 CONNECTING THE CONDUCTIVITY CELL TO THE INPUT A

-  The connection of the cell is the most critical part of the whole system. Even accidental application of extraneous voltages to the measurement process can damage the circuits:
- use only the cables supplied with the sensor;
  - avoid interruptions of the cables. For cable extension use only special blocks at a very high insulation and protection from moisture;
  - very long connections may require "zero" compensation in case of low conductivity values;
  - keep the cable of the cell far from the power cables also inside the switch board.

#### Two electrodes cell

Connect the cell to terminals 22 and 20 marked CO and CI.

In case of coaxial cell connect the central electrode to the terminal 20 marked CI and the external electrode to the terminal 22 marked CO.

#### Four electrodes cell

Refer to the manual of the option 091.1382 " regarding the 4 electrodes input option" and the manual of the cell used.

### 5.6.3 CONNECTING THE SENSORS TO INPUT B AND C

The connection of pH /ORP / ISE electrodes is the most critical part of the whole system.

The sensing pH or ORP electrodes are connected to the central wire of their coaxial cable.

The reference electrodes are connected to the shield of their coaxial cable.

#### Input B

- Connect the central of the coaxial cable to the terminal 14 marked HI.
- Connect the shield of the coaxial cable to the terminal 15 marked LO.

#### Input C

- Connect the central of the coaxial cable to the terminal 23 marked HI.
- Connect the shield of the coaxial cable to the terminal 24 marked LO.

Use only the original cables supplied by the manufacturer to connect the sensors to the input terminals of the instrument.

 The connecting cable generally has a conductive black sheath, very thin, between the central conductor and the shield. Remove this sheath for at least 5 mm to avoid contact with the fixing pin of the central conductor of the cable.

 In case the sensor is not connected to the B and/or C input, it is necessary to place a jumper between the terminals marked HI and LO.

### 5.6.4 CONNECTING THE TEMPERATURE SENSOR

To get the display of the temperature value and the automatic compensation of the effect of temperature on the pH measurement is necessary to connect the temperature sensor Pt100 or Pt1000 as shown in chapter "Connection diagram (page 97)", using the appropriate wire section.

If the temperature sensor is not connected, interrupted or in short circuit, the instrument automatically switches to the manual temperature compensation.

#### Two-wire Pt100 / Pt1000 connection for short distances

- Connect the Pt100 / Pt1000 to terminals 17-18 (marked T2-T1) and install a jumper between 16-17 (marked T0-T2).

#### Three wire Pt100 / Pt1000 connection for great distances

- Connect a Pt100 / Pt1000 wire to terminal 18 marked T1.
- Connect the Pt100 / Pt1000 common wire to terminal 16 marked T0 and to terminal 17 marked T2 using two separate wires.



Do not interrupt the connecting cable. Use extension cable fastened on high insulation junction box.

Keep the cable away from the power cables.

In case of interference use shielded cable, connecting the shield to ground terminal 3.

### 5.6.5 CONNECTING THE ANALOG OUTPUTS

The instrument provides two output current signals to drive an external recorder, PLC or other similar devices.

- Connect the (+) of the recorder N°1 to the terminal 30 marked R1 +.
- Connect the (+) of the recorder N°2 to the terminal 31 marked R2 +.
- Connect the (-) of the recorder to the terminal 29 marked R0 -.

If the analog output signal is to drive several devices, they must be connected in "series" with each other. The sum of their input resistances must not exceed 600  $\Omega$ .

As alternative, the outputs can be used for PID control, and then connected to actuators with analog 4/20 mA or 0/20 mA input.



Do not give any external power to the analog output terminals. It will damage the circuits of the instrument.

### 5.6.6 CONNECTING THE SERIAL PORT RS 485

The instrument has a serial port for the communication of all measurements and parameters. It works as a slave device with two types of protocol as reported in chapter "Digital operation (page 87)".

- Connect the positive RS 485 interface to the terminal 39 marked A+.
- Connect the negative RS 485 interface to the terminal 38 marked B-.
- Connect the ground RS 485 interface to the terminal 37 marked GND.

### 5.6.7 CONNECTING PUMPS, SOLENOIDS AND ALARMS

The 4 relays can be used for the regulation of the three main measures if configured in the system configuration menu.

The contacts of the relays are available on the dedicated terminal block.

They consist of two normally open SPST contacts for relay 1 and relay 2.

They consist of two SPDT contacts for relay 3 and 4.

For the alarm function must use the relay 3.

For the cleaning function must use the relay 4.

#### RELAY 1

terminal 5 marked C : common

terminal 4 marked NO : normally open

This relay is normally used for the SET 1 or SET 2.

#### RELAY 2

terminal 7 marked C : common

terminal 6 marked NO : normally open

This relay is normally used for the SET 1 or SET 2.

#### RELAY 3

terminal 9 marked C : common contact

terminal 8 marked NO : normally open contact

terminal 10 marked NC : normally closed contact

This relay is normally used for the alarm but can be used for the SET1 and SET2.

The alarm relay can be configured on / off status (ACTIVE / NOT ACTIVE) when in alarm status.

The NON ACTIVE allows to indicate the switching off or non-operation of the instrument  
The alarm condition occurs when:

exceeding the min / max values;

exceeding the persistence of set point 1 and 2 if configured;

contact of logic input 1 and 2 if configured.

#### RELAY 4

terminal 12 marked C : common contact

terminal 11 marked NO : normally open contact

terminal 13 marked NC : normally closed contact

This relay is normally used for the sensor cleaning function but can be used for the SET1 and SET2 or the degassing function.

Power the load of the relays from different source than the instrument in order to prevent interferences due to the inductive loads.

If necessary use snubbers.

Protect the relay contacts by fuse.

Do not exceed the rated current value of the contacts (5 A resistive).

The set point values can be changed if it was not inhibited the calibration in the setup menu. (See chapters and "Setup (page 77)").

To modify the min/max function and the regulation type of the set points see the chapter .

Set points and alarm feature the delay setting (see "Setup (page 77)").

### 5.6.8 CONNECTING THE LOGIC INPUTS

Apply free voltage contacts (in closure) from an external device to the logic input terminals 27-28 (marked D1-D+) and 26-28 (marked D2-D+).

The activation and the configuration of the logic input are described on the display S6.1 () and C6.1 ("Configuration (page 81)").

The hold or alarm function are described in the chapter "Technical specification (page 23)".

### 5.6.9 NETWORK CONNECTION (RS485)

This instrument uses a RS485 driver with slow switching fronts.

For this reason it is not necessary to complete the termination of the transmission line even for long distances.

The following indications are to be considered as examples.

If the driver of the master device has very fast switching fronts, it may be necessary to terminate the beginning and end of the transmission line. In this case it should be inserted in the transmission line a pull-up and pull-down  $R_p$  resistors to keep the line polarized and to ensure the starting condition (start bit).

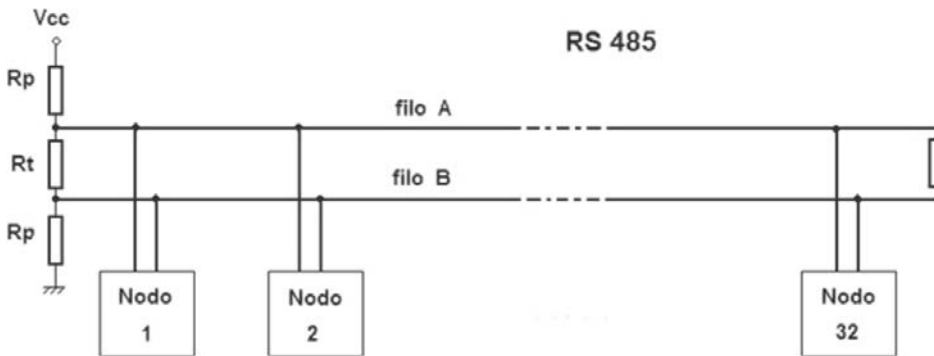

*Termination with pull-up and pull-down resistances.*

If the power supply to insert the pull-up and pull-down resistances is not available or you do not want the driver over charge, make an AC termination by inserting a capacitor in series with the termination resistor.

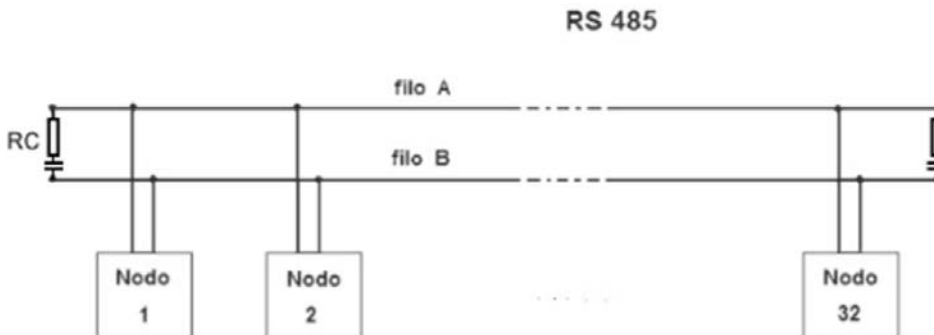

*AC termination*

## 5.7 DISPOSAL

In case of disposal of the instrument, apply the terms of the law provided for the disposal of electronic devices.

## 6 OPERATING PROCEDURE

### 6.1 MEASUREMENT OF THE CONCENTRATION OF SPECIFIC IONS

The method of measuring the concentration of specific ions in water used in this instrument is based on special sensors called ISE (ion selective electrode) .:

These sensors are of the potentiometric type and consist of two electrodes: sensitive ion electrode and reference electrode.

The ion sensitive electrode provides a potential dependent on the ion concentration which is detected with the aid of the reference electrode.

In the most common cases, the two electrodes are assembled in one body to form a combined electrode.

The potential provided by the ISE electrode responds, similarly to the pH electrode; to Nernst's law which is logarithmic and depends on the valence of the ion.

The ions can be positive or negative, monovalent or bivalent type, each of which provides a corresponding signal.

The measuring instrument reads the potential difference provided by the type X +, X ++, X-, X-- ISE sensor and converts it into concentration by applying the antilogarithm.

The slope of the bivalent sensors, for each decade of concentration, is about half the slope of the monovalent ions as they carry two electrical charges.

The measuring instrument must be configured to match the valence of the ion (X +, X ++, X-, X--) and must undergo the first initial two-point calibration.

Since the response of the ISE sensors is not identical over the various decades of operation, the B&C Electronics instrument can be calibrated in five different concentration decades.

ISE sensors suffer interference from other ions present in the sample which alter the signal they provide.

The user will have to consider on a case-by-case basis the extent of these interferences based on the technical specifications of the sensor and the sample content.

The temperature influences the ionic activity of the solution and with it the signal provided by the sensor, which is why the compensation function of the temperature effect should be used in applications where the liquid temperature is significantly different from the reference value of 20 ° C.

The user needs to evaluate the installation of a temperature probe in order to perform the automatic compensation in case the temperature undergoes large changes.

## 6.2 MEASUREMENT OF THE PH AND ORP

In the pH measurement the instrument receives a mV signal from the sensor and provides the value in pH units, in accordance with the Nernst law relating to the type of sensor used.

In the ORP measuring, the instrument receives a mV signal from the sensor and provides the value in mV.

In both cases, you can make the zero and sensitivity adjustment to compensate the changes of the sensor response due to the conditions of use.

The temperature influences the ion activity of the solution and with it the signal provided by the sensor.

For this reason, in the pH measurement must be used the temperature compensation in applications where the temperature of the sample is significantly different from the reference value of 20 °C.

It is necessary to consider the installation of a thermoresistance and the use of the automatic temperature compensation in case of important changes.

## 6.3 MEASUREMENT OF THE CONDUCTIVITY

The instrument is used to measure the electrical conductivity of a liquid that depends on the ionic concentration in solution.

The conductivity measurement is carried out by means of a cell with two electrodes of geometric size defined and completely surrounded by the liquid to which an alternating voltage of appropriate frequency is applied, to avoid polarization of the same caused by electrochemical effects.

Electrode geometry defines the cell constant, normally referred to as "K".

Normally it is used a cell having the value  $K = 1$ , but this instrument can work with conductivity cells having values  $K = 0.01$ ,  $K = 0.1$ ,  $K = 0.5$  and  $K = 10$  in order to obtain measurements in a very wide range.

The type of electrodes material sets limits on the choice of the measurement scale normally indicated in the specifications of the cell itself.

The temperature of the solution has a significant influence on the measurement as it depends on the ionic activity of the substances present in the sample.

There is therefore a significant increase in conductivity as the temperature increases even if the sample content remains constant.

In many cases, it is important to have a temperature-independent conductivity measurement and refer to a conventional temperature (20 °C or 25 °C). It is necessary to use the automatic compensation of the temperature effect, by detecting the temperature with a sensor immersed in the sample and the electronic correction of the measured conductivity value.

In the case of very high conductivity values, a four electrodes cell should be used in order to obtain good linearity and a wide degree of independence from the electrodes dirty conditions.

## 6.4 MEASUREMENT OF THE PURE WATER CONDUCTIVITY

This instrument measures the conductivity of ultrapure water taking into account the conductivity of the same at the temperature considered and the conductivity of the pollutant.

The value of the conductivity of the ultrapure water as a function of the temperature is stored in a table and the compensation of the effect of the temperature caused by the pollutant is carried out by means of a temperature coefficient selected by the user. The unit uses the equation:

$$C_{Tref} = \frac{C_t - C_{wt}}{1 + Tc(t - Tref)} + C_{wTref}$$

- $C_{Tref}$  conductivity at the reference temperature (20, 25 °C)
- $C_t$  conductivity at the operating temperature
- $C_{wt}$  ultra pure water conductivity at the operating temperature
- $C_{wTref}$  ultra pure water conductivity at the reference temperature
- $t$  operating temperature
- $Tref$  reference temperature (20, 25 °C)
- $Tc$  temperature coefficient of the dissolved ions

Therefore the conductivity of the sample at the selected reference temperature is equal to the sum of the conductivity due to the pollutant (temperature compensated value) and the conductivity of the ultrapure water at the reference temperature.

The temperature/conductivity table used for ultrapure water is the following:

°C	0	10	20	30	40	50	60	70	80	90	100
nS	11.6	23.0	41.9	71.0	113.5	172.1	249.8	348.6	469.4	611.4	770.9
Mohm	86.3	43.4	23.9	14.1	8.8	5.8	4.0	2.9	2.1	1.6	1.3

## 6.5 MEASUREMENT OF THE TDS

TDS (total dissolved solids) measurements are required in particular applications to know the impurities present in the solution that can create incrustations (such as in boilers or cooling towers) or in solutions with high salinity such as in sea water.

The measurement method consists of evaporating a liter of sample from which the solids are removed/filtered, and weighed the dry residue.

However, for practical and economic reasons, an indirect measurement is carried out continuously by the conductivity measurement that is converted by the instrument into ppm or mg/l, multiplying the conductivity value for the conversion coefficient.

Therefore, the validity of the measure is closely related to the correctness of that coefficient.

Depending on the applications, three different conversion coefficients are used, referring to solutions containing sodium chloride, potassium chloride or a mixture called 442 (consisting of 40% sodium sulphate, 40% sodium bicarbonate and 20% sodium chloride). It should be noted that the conversion coefficients vary depending on the concentration of the solution.

For example, in solutions at 25 ° C with conductivity from 80  $\mu$ S to 80 mS the coefficients vary as follows:

- NaCl: from 0.475 to 0,605;
- KCl: from 0,505 to 0,650;
- 442: from 0,655 to 0,995.

The instrument allows you to measure the TDS by entering a selectable conversion coefficient within a wide range of values.

The TDS-configured instrument keeps all the adjustment, alarm and analogue outputs present in the conductivity measurement.

Calibrations should instead be carried out in the conductivity scale corresponding to the TDS scale, by using standard conductivity solutions.

However, it is possible to fine-tune the coefficient by entering the value of a known solution or by comparing it with a field instrument.

## 6.6 INDIRECT MEASUREMENT OF THE CONCENTRATION

The concentration measurement is required in particular applications with solutions that contain predominantly one type of electrolyte such as hydrochloric acid, sulfuric acid, nitric acid, sodium hydroxide, calcium chloride, and so on.

The measurement method consists of a specific laboratory analysis for each type of substance.

However, in some cases, an indirect measure is continuously carried out using the conductivity measurement that is converted to %, ppm, mg / l, gr / l etc. by a conversion table.

The instrument allows you to carry out the concentration measurement (indirect measurement) by inserting a conversion table of up to 8 points.

In this configuration it keeps all the adjustment, alarm and analog outputs present in the conductivity measurement.

Calibrations should instead be carried out in the conductivity scale corresponding to the concentration scale, using standard conductivity solutions.

However, it will still be possible to fine-tune the conversion by entering the value of a known or comparing with the laboratory analysis.

## 6.7 MEASUREMENT OF THE RESISTIVITY

The electrical resistivity is the attitude of a material to resist to the passage of electric charges and same as the conductivity it depends on the ionic concentration in solution.

The instrument allows the display of the resistivity and the conductivity value from which it is calculated and on which the adjustments will be made.

The measure of resistivity is usually used for the characterization of ultrapure waters.

## 6.8 DISPLAY

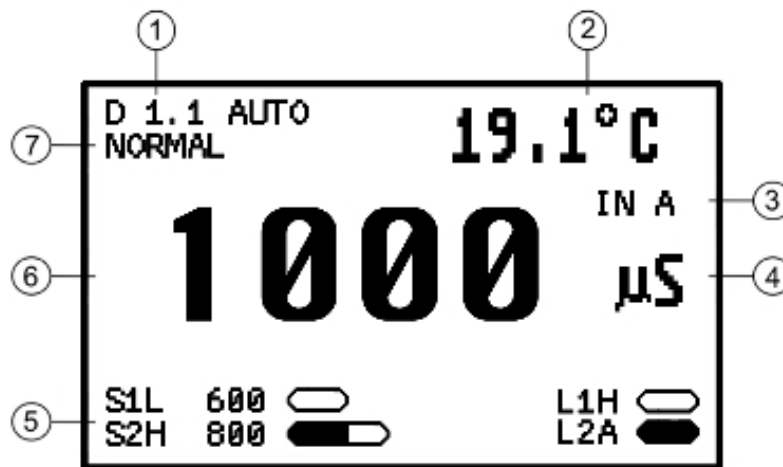

- |   |  |
|---|--|
| <p>1. Display ID</p> <p>2. Operating mode</p> <p>3. Secondary display</p> <p>4. Measuring information</p> | <p>5. Information display (set points and analog inputs status; functions and messages)</p> <p>6. Main display</p> <p>7. Instrument status: NORMAL, CLEAN, HOLD, ALARM (MEAS/S1/S2/L1/L2),HN</p> |
|---|--|

## 6.9 KEYBOARD

KEYS	FUNCTION
ZERO	- To access the zero calibration
SENS	- To access the sensitivity calibration
SET 1	- To access the set point 1 setting
SET 2	- To access the set point 2 setting
MODE	- To visualize the available displays - To exit from the not confirmed calibrations sequences
^	Key "UP" - To modify (increase) the displayed data - To turn the unit to the main display
∨	Key "DOWN" - To modify (decrease) the displayed data - To not return to the main display (valid only for D1.1, D1.2, D1.3)
ENT	- To enter the effected changings and selections

## 6.10 USERS INSTRUCTION

### 6.10.1 MAIN DISPLAY

The display shows the measured values of the inputs A, B, C, the temperature and the logic inputs status.

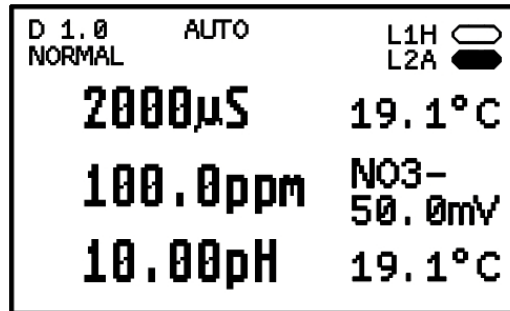

If the user has enabled the cleaning function, during the cleaning cycle will show the value of the measure and the cleaning phase in progress: CLEAN or HOLD.

Symbol map	
	Active relay or input
	Non active relay or input
	Relay's activation delayed
	Proportional activation level (PID)

### 6.10.2 INPUT A MEASURING

Pressing the MODE key from the D1.0 display will be possible to display the measured value on input A (conductivity) and access the calibration procedures and the set point, if have not been reserved to the maintenance staff.

If the measurement in TDS or in indirect scale are activated, the display shows the value in these scales.

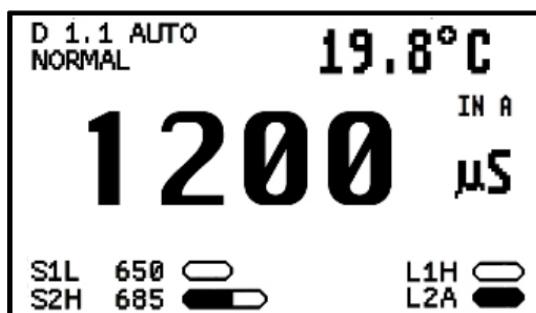

### 6.10.3 INPUT B MEASURING

By pressing twice the key MODE from D1.0 display it will be possible to display the value of the input B (ISE/pH / ORP) and access the calibration procedures, the set point, if these have not been reserved the maintenance staff.

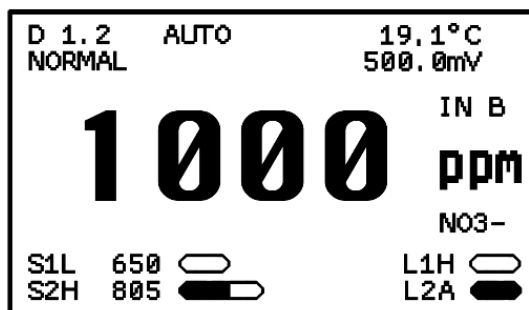

### 6.10.4 INPUT C MEASURING

Pressing three times the key MODE from D1.0 display will be possible to display the value of the input C (ISE/pH / ORP) and access the calibration procedures, the set point, if these have not been reserved the maintenance staff.

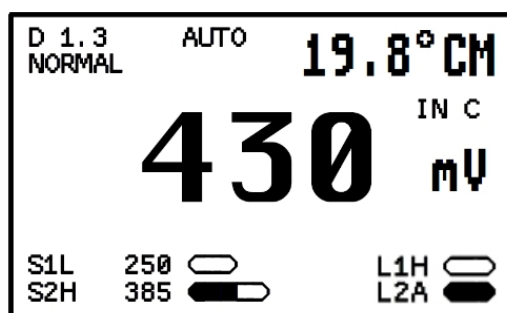

### 6.11 TEMPERATURE MEASURING

Press four times the MODE key from the display D1.0 to visualize the temperature value and to access the sensor calibration (if any).



### 6.11.1 ANALOG OUTPUT 1 VALUES

Press MODE five times from the display D1.0 to visualize the output signal and the corresponding current value.

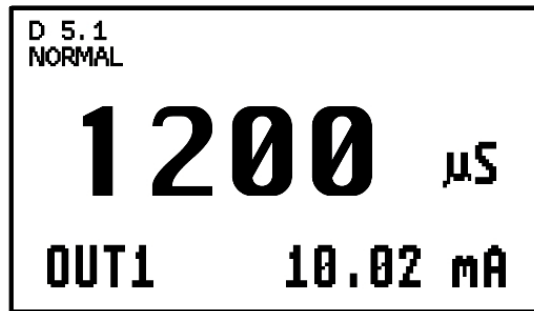

### 6.11.2 ANALOG OUTPUT 2 VALUES

Press MODE six times from the display D1.0 to visualize the output signal and the corresponding current value.

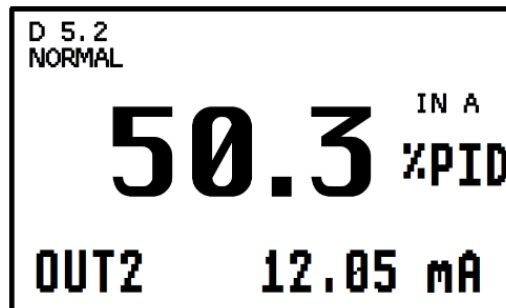

### 6.11.3 AUTOCLEAN

Press MODE seven times from the display D1.0 to visualize the autoclean status, the remaining time to the next cycle and the repetition time as configured in the setup menu. This function is available if assigned to relay 4.

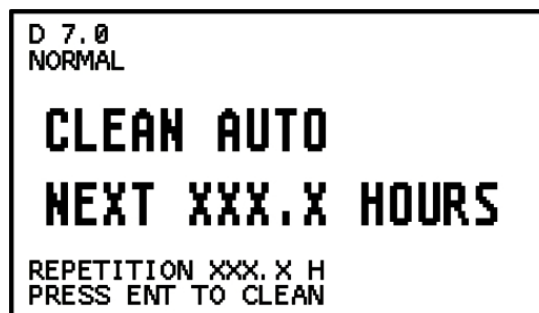

ENT	to start a cleaning cycle.
-----	----------------------------

### 6.11.4 PARAMETERS FOR THE MAINTENANCE

Press MODE eight times (seven if clean function is not active) from the display D1.0 to visualize the SETUP display to access the maintenance menu of the unit.



### 6.11.5 PARAMETERS FOR THE PLANT ENGINEER

Press MODE nine times (eight if clean function is not active) from the display D1.0 to visualize the CONFIGURATION display to access the installation menu of the unit.

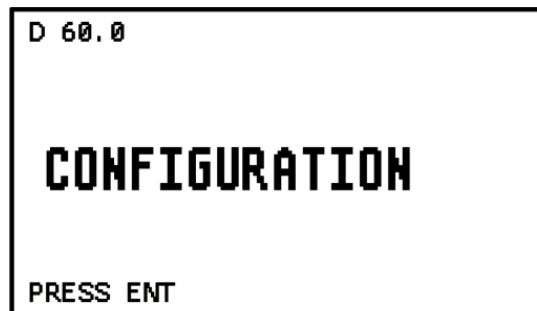

### 6.11.6 INFORMATION MENU

Press MODE ten times (nine if clean function is not active) from the display D1.0 to visualize the information menu from which you can access the information functions of the instrument.



- |            |  |
|------------|--|
| ENT        | press the key to visualize and to confirm in sequence the setup parameters |
| UP or DOWN | press the key to modify the values   |
| MODE       | press the key to turn to the D70.0 display any time                        |

Display	Contents	Meaning	Possible values
11.0	B&C electronics CL6587 R1.00	P/N e firmware release	
12.0	LCD BRIGHTNESS 8	Screen brightness	0 ÷ 30
13.0	LCD CONTRAST 8	Screen contrast	0 ÷ 30
14.0	LCD MODE NORMAL	Type of visualization of the screen	NORMAL REVERSE
15.0	TOTAL: XXXXX h	Total operating hours	

## 6.12 MAINTENANCE INSTRUCTION

### 6.12.1 PRELIMINARY OPERATIONS

All the functioning operations must be done with sensors or simulator connected to the unit.

Verify if the configuration, the set point and the alarm parameter are suitable for the current application.

Follow the procedures described in the chapter "Setup (page 77)" to verify the parameters without modifying the values.

In the setup of the system, you can enable / disable the ability to perform calibration of the sensors and change the values of set point and alarm.

The display allows the operator to perform the preliminary check.

The lit display indicates that the unit is powered and the power circuits work correctly.

### 6.12.2 MEASURING OPERATIONS

In order to operate the system, verify previously the following:

- the sensors are connected and in operation;
- the power and the ground are connected;

and if necessary

- the analog outputs;
- the loads of relays 1 and 2;
- the alarm relay;
- the logic inputs.

Supply mains power to the instrument and observe the measurement values and the set point status signals on the display as required by the configuration.

If the sensors are connected as described in the chapter "Installation (page 48)", the system will work correctly and it will need just the calibration, the set points and alarm values selection.

### 6.12.3 CALIBRATION

To perform zero and sensitivity calibration go to the D1.x display of the desired channel and use ZERO and SENS keys to start the calibration.

Follow the sequence of operations suggested by the instrument firmware, proper of each selected parameter, using the UP, DOWN and ENT keys.

### 6.12.4 CALIBRATION OF THE CONDUCTIVITY (INPUT A)

#### 6.12.5

Install the measuring cell and connect it to the instrument.

Zero calibration and sensitivity calibration can be performed on the conductivity measurement.

#### Zero calibration

Zero calibration, if necessary, is carried out by keeping the cell dry in air.

If there is no effect due to the length and type of connection cable, the value of the measurement with the cell in the air should already indicate the zero value.

Contact our technical sales department in case of very high zero values.

On the display D1.1A press the key ZERO to get the following display:

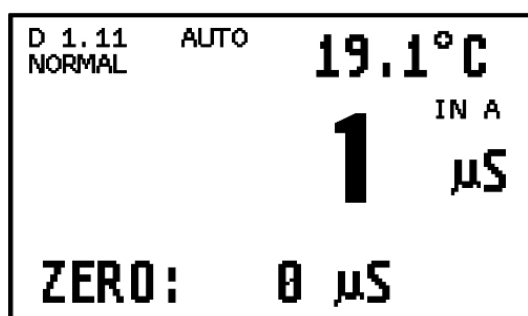

UP and DOWN to change the displayed value

ENT to confirm the displayed value

On the information display will appear UPDATE message or error message if the calibration is not successful.

 *The user can reset to zero factory as follows:  
start the calibration of zero, simultaneously press UP, DOWN and ENT.*

#### Sensitivity calibration

The instrument is supplied with factory electrical calibration which is equivalent to using a measuring cell with  $K = 1$ .

The calibration of the sensitivity allows to compensate the cell K value different from the nominal one.

Normally a KCl solution of known concentration is used, chosen within the measurement range in which one wants to operate.

On the display D1.1A press the key SENS to get the following display:

**KCl STANDARD:** if you choose to calibrate with the KCl standard solution, you are asked whether the temperature compensation is performed automatically (AUTO) or manually (MAN) at a set value. The instrument calibrates by applying the temperature coefficient of the KCl which can be different from the one set for the temperature compensation of the sample under examination. This means that after calibration, a value of the standard measurement slightly different from that of the standard itself is displayed;

**MEASURE ADJ:** if you choose to calibrate the conductivity value by comparison, you are asked if the temperature compensation is carried out automatically (AUTO) or manually (MAN) at a set value. The instrument calibrates by applying the temperature coefficient set for the solution under examination;

**SENS ADJ:** if you choose to set the nominal value of the cell. This method is especially used in ultrapure water applications due to the difficulty of obtaining reliable reference standards.

UP and DOWN    to change the displayed value  
ENT                to confirm the displayed value

D 1.15	AUTO	19.8°C
NORMAL		
1200 µS	TR=20°C	
TC=2.08%/°C	KCl	
SENS: 99.4%		

D 1.15	AUTO	19.8°C
NORMAL		
1200 µS	TR=20°C	
TC=2.20%/°C	TAB	
SENS: 99.4%		

D 1.16	AUTO	19.1°C
NORMAL		
SENS: 99.4 %		
SENS ADJ		
SENS: 99.4 %		

UP and DOWN    to change the displayed value  
ENT                to confirm the displayed value

On the information display will appear UPDATE message or error message if the calibration is not successful.

 *The user can reset to sensitivity factory as follows:  
start the calibration of sensitivity, simultaneously press UP,  
DOWN and ENT.*

### One point calibration

In almost all cases it may be considered sufficient to perform only the sensitivity calibration which must be carried out with the methods indicated in the previous chapter.

### Error messages

The error messages during the calibration inform the user that the sensor is in unacceptable operating condition and therefore risky for the plant.

Deviations of zero value above +/- 20% of full scale and deviations of the sensitivity under 12.5% or above 250% of full scale, are considered errors.

In the event of these messages it is advisable to carry out checks on the sensor, clean the electrodes or install a new one.

## 6.12.6 TDS CALIBRATION

On TDS measure it can be done zero and sensitivity calibration.

### Sensitivity calibration

The instrument comes with a factory configuration with a conversion coefficient of 0.670 that can be edited in the configuration menu.

Sensitivity calibration allows to change the conversion coefficient to show on the display the value of the standard solution used or the laboratory value or that of a reference instrument.

Press SENS to get the following display:



UP and DOWN to change the displayed value

ENT to confirm the displayed value

On the information display will appear UPDATE message or error message if the calibration is not successful.

 *The user can reset to sensitivity factory as follows:  
start the calibration of sensitivity, simultaneously press UP,  
DOWN and ENT.*

## 6.12.7 INDIRECT MEASURE CALIBRATION

On main measure it can be done zero and sensitivity calibration.

### Sensitivity calibration

This calibration can be performed when the conductivity/concentration conversion table has been inserted into the configuration menu.

Sensitivity calibration allows to obtain on the display the value of the sample concentration obtained by the laboratory or known by the user.

This calibration does not change the table curve and applies the resulting percentage variation on all points of the table.

Press SENS to get the following display:

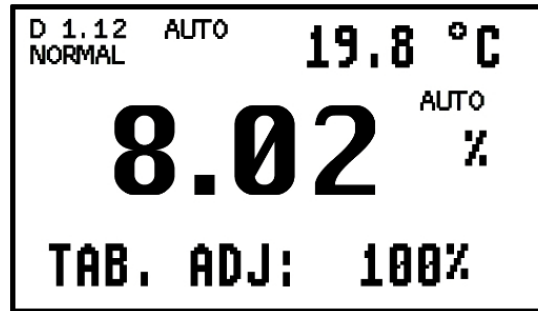

UP and DOWN to change the displayed value  
ENT to confirm the displayed value

On the information display will appear UPDATE message or error message if the calibration is not successful.

 *The user can reset to sensitivity factory as follows:  
start the calibration of sensitivity, simultaneously press UP,  
DOWN and ENT.*

### 6.12.8 ISE CALIBRATION (INPUTS B AND C)

The procedures described below are applicable to input B and C in case an ISE sensor is connected.

Before calibration (also called electrodes standardization), check that the glass membrane of the sensor was kept moist during storage.

If the protective reservoir is empty and the glass membrane is dry, immerse the electrode in a buffer solution or in tap water (do not use distilled water) for at least three hours before proceeding.

In any case, follow the instructions of the manufacturer of the electrode.

To make the standardization of the pH electrodes you can use the buffer solutions from B&C Electronics.

#### Zero calibration

Place the electrode in solution at pH = 7 (SZ 954) to calibrate the 1st point (Zero calibration).

Press ZERO to get the following display:

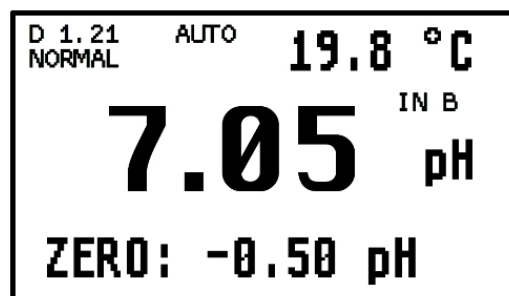

UP and DOWN to change the displayed value

ENT to confirm the displayed value

On the information display will appear UPDATE message or error message if the calibration is not successful.

 *The user can reset to zero factory as follows:  
start the calibration of zero, simultaneously press UP, DOWN and ENT.*

## Sensitivity calibration

Place the electrode in solution at pH = 4 (SZ 952) or pH = 9 (SZ 956) to calibrate the 2nd point (Calibration of sensitivity).

Press SENS to get the following display:

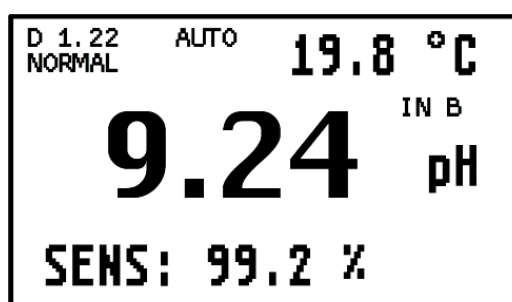

UP and DOWN to change the displayed value

ENT to confirm the displayed value

On the information display will appear UPDATE message or error message if the calibration is not successful.

 *The user can reset to sensitivity factory as follows:  
start the calibration of sensitivity, simultaneously press UP,  
DOWN and ENT.*

## One point calibration

In some cases it may be considered sufficient to perform a one point calibration with a buffer solution of value close to the average measure.

In this case follow the zero calibration procedure.

## Error messages

The error messages during the calibration inform the user that the pH electrode is in unacceptable operating condition and therefore risky for the plant.

In fact a deviation of zero > 2 pH is indicative of excessive pollution of the reference electrode.

A deviation of sensitivity < 80 % or > 110 % indicates an exhausted electrode or losses in connection cable.

In these situations is suggested to replace the electrode.

- ⚠ If the value of the standard solution is different from expected it may mean that:
- the real value of the buffer used is very different from the nominal one (the solution is polluted or altered);
  - the electrode is not operating normally (broken, badly installed).

The calibration of the pH meter in case of temperature compensation requires special precautions:

- consider the value of pH of the buffer at the operating temperature;
- detect the value of the temperature of the solution;
- wait for the stabilization of the temperature measurement.

### 6.12.9 PH CALIBRATION (INPUTS B AND C)

The procedures described below are applicable to input B and C in case a pH sensor is connected.

Before calibration (also called electrodes standardization), check that the glass membrane of the sensor was kept moist during storage.

If the protective reservoir is empty and the glass membrane is dry, immerse the electrode in a buffer solution or in tap water (do not use distilled water) for at least three hours before proceeding.

In any case, follow the instructions of the manufacturer of the electrode.

To make the standardization of the pH electrodes you can use the buffer solutions from B&C Electronics.

#### Zero calibration

Place the electrode in solution at pH = 7 (SZ 954) to calibrate the 1st point (Zero calibration).

Press ZERO to get the following display:

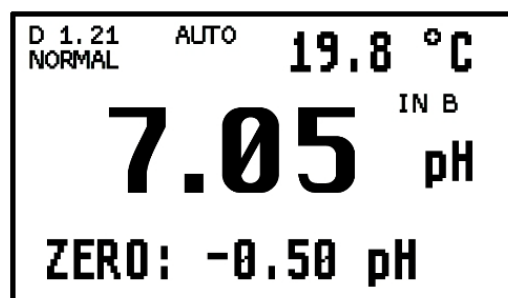

UP and DOWN      to change the displayed value

ENT                to confirm the displayed value

On the information display will appear UPDATE message or error message if the calibration is not successful.

-  *The user can reset to zero factory as follows:  
start the calibration of zero, simultaneously press UP, DOWN and ENT.*

## Sensitivity calibration

Place the electrode in solution at pH = 4 (SZ 952) or pH = 9 (SZ 956) to calibrate the 2nd point (Calibration of sensitivity).

Press SENS to get the following display:

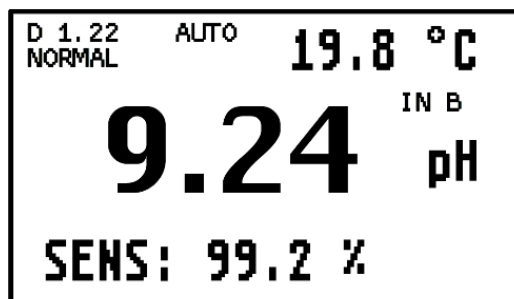

- UP and DOWN    to change the displayed value  
ENT              to confirm the displayed value

On the information display will appear UPDATE message or error message if the calibration is not successful.

-  *The user can reset to sensitivity factory as follows:  
start the calibration of sensitivity, simultaneously press UP,  
DOWN and ENT.*

## One point calibration

In some cases it may be considered sufficient to perform a one point calibration with a buffer solution of value close to the average measure.

In this case follow the zero calibration procedure.

## Error messages

The error messages during the calibration inform the user that the pH electrode is in unacceptable operating condition and therefore risky for the plant.

In fact a deviation of zero > 2 pH is indicative of excessive pollution of the reference electrode.

A deviation of sensitivity < 80 % or > 110 % indicates an exhausted electrode or losses in connection cable.

In these situations is suggested to replace the electrode.

- ⚠ If the value of the standard solution is different from expected it may mean that:
- the real value of the buffer used is very different from the nominal one (the solution is polluted or altered);
  - the electrode is not operating normally (broken, badly installed).

The calibration of the pH meter in case of temperature compensation requires special precautions:

- consider the value of pH of the buffer at the operating temperature;
- detect the value of the temperature of the solution;
- wait for the stabilization of the temperature measurement.

## 6.12.10ORP CALIBRATION (INPUTS B AND C)

The procedures described below are applicable to input B and C in case of a ORP sensor is connected.

In general it is preferable to operate with the factory calibration in order to measure the actual values supplied by the ORP electrode.

Should calibration be necessary is advisable to perform only zero calibration.

If the sensing part is dry, soak the electrode in tap water (do not use the distilled water) for at least three hours before proceeding.

In any case, follow the instructions of the manufacturer of the electrode.

To standardize the ORP electrode you can use the standard solution of the B&C Electronics.

### Zero calibration

Place the electrode in the standard solution at  $mV = 220$  (SZ 961) to calibrate the 1st point (Zero calibration).

Press ZERO to get the following display:

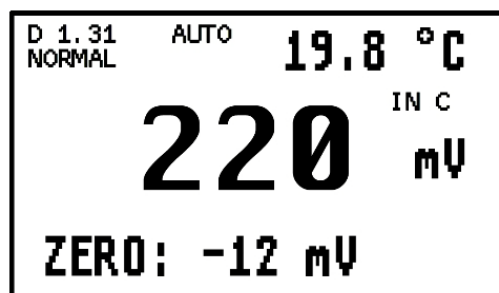

UP and DOWN    to change the displayed value

ENT              to confirm the displayed value

On the information display will appear UPDATE message or error message if the calibration is not successful.

-  *The user can reset to zero factory as follows:  
start the calibration of zero, simultaneously press UP, DOWN and ENT.*

## Sensitivity calibration

If the sensitivity calibration is necessary, place the electrode in the second standard solution.

Press SENS to get the following display:

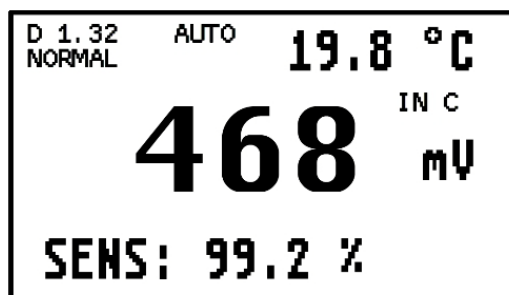

- UP and DOWN    to change the displayed value  
ENT                to confirm the displayed value

On the information display will appear UPDATE message or error message if the calibration is not successful.

-  *The user can reset to sensitivity factory as follows:  
start the calibration of sensitivity, simultaneously press UP,  
DOWN and ENT.*

## Error messages

The error messages during the calibration inform the user that the ORP electrode is in unacceptable operating condition and therefore risky for the plant.

In fact a deviation of zero > 100 mV is indicative of excessive pollution of the reference electrode.

A deviation of sensitivity < 70 % or > 140 % indicates an exhausted electrode or losses in connection cable.

In these situations is suggested to replace the electrode.

-  If the value of the standard solution is different from expected it may mean that:
- the real value of the buffer used is very different from the nominal one (the solution is polluted or altered);
  - the electrode is not operating normally (broken, badly installed).

## 6.12.11 TEMPERATURE CALIBRATION

### Temperature sensor connected

It can be done when the temperature sensor is connected to the unit.

Immerse the sensor in a liquid or keep the sensor in the air knowing the value of the temperature.

On the display D2.0 press the key ZERO and it will appear the calibration display:

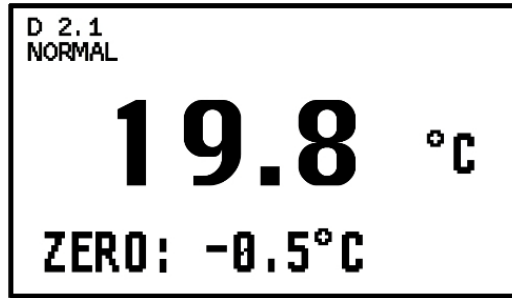

UP and DOWN    press to change the displayed value  
ENT                press to confirm the displayed value

On the information display will appear UPDATE message or error message if the calibration is not successful.

 *The reset to factory value in the main display is done as follows: start the calibration of temperature, simultaneously press the UP, DOWN and ENT.*

### Temperature sensor not connected

The temperature for the manual compensation can be changed in the setup menu, refer to the chapter "Setup (page 77)".

## 6.12.12 SET POINT

Pressing the key SET1 or SET2 on D1.1, D1.2, D1.3 display will see the following display (the example refers to the set point 1 of the input A):

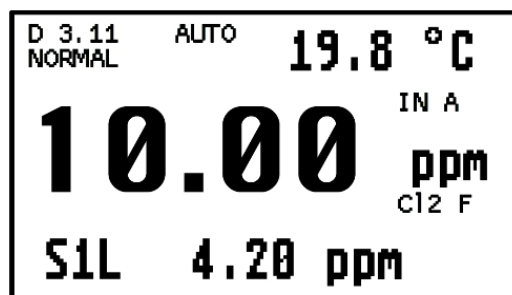

UP and DOWN    to change the displayed value  
ENT                to confirm the displayed value

## 6.12.13SETUP

Since the instrument has three independent measuring channels you need to select the input on which to operate.

Press MODE eight times from the D1.0 display to go to the D50.0 display (seven times if the clean function is not activated).



### Sequence to access setup menu

- ENT                    press to enter the password
- UP and DOWN      press to select system, input A, input B or input C setup
- MODE                press to confirm
- ENT                    press to display and confirm the sequence of the setup parameter of the unite
- UP and DOWN      press to change the displayed value
- MODE                press to turn to the D50.3 display any time

 Depending on the configuration of the instrument the setup parameters may not be visualized.

*The display on the top left of each screen identifies the input on which you are working.*

Display	Contents	Meaning	Possible values
D50.1	PASSWORD SET-UP ---	Password to access the setup menu	000 ÷ 999
S1.1	CAL FUNCTION ON	Inhibition of the zero and sensitivity calibration and set point changings	ON OFF
S2.1	TEMP. UNIT °C	Temperature measuring unit	°C °F
S2.2	TEMP. MANUAL 20.0 °CM	Manual temperature compensation	Variable
S6.1	LOGIC INPUT1 OFF	Logic input 1 setting	ON OFF
S6.2	LOGIC INPUT2 OFF	Logic input 2 setting	ON OFF

Display	Contents	Meaning	Possible values
S7.1	CLEAN OFF	Cleaning function activation	OFF AUTO MANUAL
S7.2	CLEAN REPETITION 24.0 h	Cleaning cycle	0.5 ÷ 100.0 h
S7.3	CLEAN TIME 15.0 s	Cleaning time	1.0 ÷ 60.0 s
S7.4	HOLD TIME 3.0 min	Holding time	0.1 ÷ 20.0 min
S50.1	PASSWORD MODIFY ---	Password change	0 ÷ 999

## Setup of the input A

Display	Contents	Meaning	Possible values
S1.1	pH MANUAL 7.00pHM	pH manual value	0.00 ÷ 14.00 pH
S2.3	TEMP. COEFFICIENT 2.00%/°C	Temperature coefficient	0.0 ÷ 4.00 %/°C
S3.1A	HYSTERESIS SET1 0.20 ppm	Hysteresis of the set point 1	Variable
S3.2A	SET1 DELAY 0.2 s	Delay of the set point 1	0.0 ÷ 99.0 s
S3.1B	PROP. BAND SET1 1.0 %	Proportional band of the set point 1 in PID function	Variable
S3.2B	INTEG. TIME SET1 0.0 min	Integral time (minutes) of the set point 1 in PID function	0.0 ÷ 999.9 min
S3.3B	DERIV. TIME SET1 0.0 min	Derivative time (minutes) of the set point 1 in PID function	0.0 ÷ 999.9 min
S3.4B	IMPULSE F. SET1 100 i/min	Pulse frequency of the set point 1 in PID (FM) function	0 ÷ 120 i/min
S3.4B	IMPULSE T. SET1 20.0 s	Pulse width of the set point 1 in PID (WM)	0 ÷ 99.9 s
S3.5A	HYSTERESIS SET2 0.20 ppm	Hysteresis of the set point 2	Variable
S3.6A	SET2 DELAY 0.2 s	Delay of the set point 2	0.0 ÷ 99.0 s
S3.5B	PROP. BAND SET2 1.0 %	Proportional band of the set point 2 in PID function	Variable
S3.6B	INTEG. TIME SET2 0.0 min	Integral time (minutes) of the set point 2 in PID function	0.0 ÷ 999.9 min

Display	Contents	Meaning	Possible values
S3.7B	DERIV. TIME SET2 0.0 min	Derivative time (minutes of the set point 2 in PID function)	0.0 ÷ 999.9 min
S3.8B	IMPULSE F. SET2 100 i/min	Pulse frequency of the set point 2 in PID (FM) function	0 ÷ 120 i/min
S3.8B	IMPULSE T. SET2 20.0 s	Pulse width of the set point 2 in PID (WM)	0 ÷ 99.9 s
S4.1	LO ALARM -1.00 ppm	Alarm relay minimum value	Variable
S4.2	HI ALARM 21.00 ppm	Alarm relay maximum value	Variable
S4.3	ALARM DELAY 1.0 s	Delay (seconds) of the alarm relay	0.0 ÷ 100.0 s

### Setup of the input B or input C

Display	Contents	Meaning	Possible values
S3.1A	HYSTERESIS SET1 0.02 pH	Hysteresis of the set point 1	Variable
S3.2A	SET1 DELAY 0.2 s	Delay of the set point 1	0.0 ÷ 99.0 s
S3.1B	PROP. BAND SET1 1.0 %	Proportional band of the set point 1 in PID function	0.0 ÷ 400.0 %
S3.2B	INTEG. TIME SET1 0.0 min	Integral time (minutes) of the set point 1 in PID function	0.0 ÷ 999.9 min
S3.3B	DERIV. TIME SET1 0.0 min	Derivative time (minutes of the set point 1 in PID function)	0.0 ÷ 999.9 min
S3.4B	IMPULSE F. SET1 100 i/min	Pulse frequency of the set point 1 in PID (FM) function	0 ÷ 120 i/min
S3.4B	IMPULSE T. SET1 20.0 s	Pulse width of the set point 1 in PID (WM)	0 ÷ 99.9 s
S3.5A	HYSTERESIS SET2 0.02 pH	Hysteresis of the set point 2	Variable
S3.6A	SET2 DELAY 0.2 s	Delay of the set point 2	0.0 ÷ 99.0 s
S3.5B	PROP. BAND SET2 1.0 %	Proportional band of the set point 2 in PID function	Variable
S3.6B	INTEG. TIME SET2 0.0 min	Integral time (minutes) of the set point 2 in PID function	0.0 ÷ 999.9 min
S3.7B	DERIV. TIME SET2 0.0 min	Derivative time (minutes of the set point 2 in PID function)	0.0 ÷ 999.9 min

Display	Contents	Meaning	Possible values
S3.8B	IMPULSE F. SET2 100 i/min	Pulse frequency of the set point 2 in PID (FM) function	0 ÷ 120 i/min
S3.8B	IMPULSE T. SET2 20.0 s	Pulse width of the set point 2 in PID (WM)	0 ÷ 99.9 s
S4.1	LO ALARM 0.00 pH	Alarm relay minimum value	Variable
S4.2	HI ALARM 14.00 pH	Alarm relay maximum value	Variable
S4.3	ALARM DELAY 1.0 s	Delay (seconds) of the alarm relay	0.0 ÷ 100.0 s

### 6.12.14 MAINTENANCE

Quality components are used to give the controller a high reliability.

The frequency of controller's maintenance depends on the nature of each particular application.



Disconnect the power supply to the unit before performing the following:

- dust removal from the terminals;
- operations on the wires connecting the terminals;
- mounting of the instrument.

As with any electronic device mechanical components such as buttons, relays, terminal blocks, are the parts most subject to failure.

- Periodically check that the device is not subject to excessive moisture.
- Check that the connections to the terminals are free of dust and corrosion.
- Check that the terminals screws are tight.
- Check that the cable glands are properly tightened.

### 6.12.15 MAINTENANCE OF SENSORS

It is recommended to perform periodical maintenance of the sensor as described below, so to avoid incorrect measurements.

The sensors must be inspected and cleaned regularly, most frequently in the case of applications in alkaline liquids, or fat-containing or organic substances.

Periodically, according to the needs of the application, perform the calibration operations.

In case of non-use for long periods, store the potentiostatic sensor and the pH and redox sensors with the protective cap attached containing the storage liquid if available or tap water. Do not use distilled water.

Store the sensors following the sensor instructions.

## 6.13 INSTALLATION INSTRUCTION

### 6.14

#### 6.14.1 SAFETY REQUIREMENTS

 After performing the installation (see chapter "Installation (page 48)"), before turning the power on and proceed to the configuration of the instrument is recommended to do the following:

- check that the terminal 3 is grounded;
- check that all connections are correct;
- check that all connections are blocked on the terminals;
- check that the mechanical fixing of the cables does not cause any twisting or bending on the terminal blocks;
- check that eventual protection fuses are of appropriate value.

 The damages due to incorrect connections during the installation are not covered by warranty.

#### 6.14.2 CONFIGURATION

Since the instrument has three independent measuring channels you need to select the input on which to operate.

Press MODE nine times from the D1.0 display to get the D60.0 display (eight times if the autoclean function is not activated).

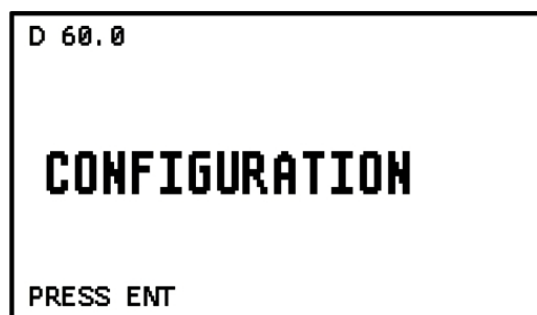

##### Sequence to access configuration menu

- |             |   |
|-------------|---|
| ENT         | press to enter the password   |
| UP and DOWN | press to select system, input A, input B or input C configuration             |
| MODE        | press to confirm  |
| ENT         | press to display and confirm the sequence of the setup parameter of the unite |
| UP and DOWN | press to change the displayed value   |
| MODE        | press to turn to the D60.3 display any time                                   |

 Depending on the configuration of the instrument, few configuration parameters may not be visualized.  
 The display on the top left of each screen identifies the input on which you are working.

## Configuration of the system

Display	Contents	Meaning	Possible values
D60.1	PASSWORD CONFIG. ---	Password to access the configuration	000 ÷ 999
C1.1	CONTROLLER MODE AUTO	Operating mode selection	AUTO MEAS SIM
C2.1	TEMP. SENSOR PT100	Pt100/Pt1000 temperature sensor type	PT100 PT1000
C3.1	RELAY 1 SET1 INPUT A	Relay 1 function	NOT USED SET 1 / 2 assigned to INPUT A / B / C
C3.2	RELAY 2 SET1 INPUT B	Relay 2 function	NOT USED SET 1 / 2 assigned to INPUT A / B / C
C3.3	RELAY 3 ALARM	Relay 3 function	NOT USED SET 1 / 2 assigned to INPUT A / B / C ALARM
C3.4	RELAY 4 CLEAN	Relay 4 function	NOT USED SET 1 / 2 assigned to INPUT A / B / C CLEAN
C4.5	ALARM FUNCTION ACTIVE	Alarm relay function if relay 3 = alarm	ACTIVE NON ACTIVE
C5.1	OUT1 INPUT A	Output 1 function	NOT USED OUT 1 assigned to IN- PUT A / B / C SET 1 / 2 assigned to INPUT A / B / C
C5.2	OUT2 INPUT B	Output 2 function	NOT USED OUT 2 assigned to IN- PUT A / B / C SET 1 / 2 assigned to INPUT A / B / C
C6.1	LOGIC INPUT1 HOLD	Logic input 1 function	HOLD ALARM
C6.2	LOGIC INPUT2 ALARM	Logic input 2 function	HOLD ALARM

Display	Contents	Meaning	Possible values
C8.1	BAUD RATE 9600	Baud rate	2400 / 4800 / 9600 / 19200 baud
C8.2	ID ASCII 32	ID B&C protocol	1 ÷ 99
C8.3	ID MODBUS 243	ID Modbus protocol	1 ÷ 243
C60.1	PASSWORD MODIFY ---	Password change	0 ÷ 999

*The SIM operating mode allows the user to change the displayed value by means of ENTER key followed by UP and DOWN keys and confirm it with ENTER key.*

## Configuration of the input A

Display	Contents	Meaning	Possible values
C1.1	SENSOR WIRING 3 WIRES	Sensor type selection	3 WIRES 2 WIRES
C1.2A	2 WIRES SENSOR C12 F	Type of measure for 2 wires sensor	C12 F C12 C C1O2 O3 CUST
C1.2B	3 WIRES SENSOR C12 F	Type of measure for 3 wires sensor	C12 F C1O2 O3 C12 T CUST
C1.3A	C12 pH COMP. AUTO	pH compensation (free chlorine)	AUTO MANUAL OFF EDIT TABLE <sup>a</sup>
C1.3B	CUSTOM SENSOR ABCDE	Custom chemical species editing	Variable
C1.4	SENSOR CURRENT 160 nA/ppm	Nominal current selection	-2000 ÷ -10 nA/ppm 10 ÷ 2000 nA/ppm
C1.5	POLARIZATION -200 mV	Polarization selection	-1000 ÷ 1000 mV
C1.6	MEASURE UNIT ppb-ppm	Units selection	ppb-ppm µg/l-mg/l

Display	Contents	Meaning	Possible values
C1.7	MEASURE SCALE 20.00 ppm	Measure range selection	200.0 ppb µg/l 2.000 ppm mg/l 20.00 ppm mg/l 200.0 ppm mg/l 2000 ppm mg/l
C1.8	RT LARGE SIGNAL 2.0 s	Large filter software time setting	0.4 ÷ 50 s
C1.9	RT SMALL SIGNAL 10.0 s	Small filter software time setting	0.4 ÷ 50 s
C1.10	HIDDEN NEGATIVE OFF	Hidden negative value selection	ON OFF
C3.1	REGUL. MODE SET1 ON-OFF	Set point 1 regulation type	ON-OFF PID
C3.2	ACTUATION SET1 FM	PID regulation related to set point 1	FM WM
C3.3	SET1 FUNCTION LO	Set point 1 function HI/LO	LO HI
C3.4	REGUL. MODE SET2 ON-OFF	Set point 2 regulation type	ON-OFF PID
C3.5	ACTUATION SET2 FM	PID regulation related to set point 2	FM WM
C3.6	SET2 FUNCTION HI	Set point 2 function HI/LO	LO HI
C4.1	ALARM SET1 OFF	Alarm activation on set point 1 operation time	ON OFF
C4.2	TIME SET1 60 min	Operation time setting	0 ÷ 60 min
C4.3	ALARM SET2 OFF	Alarm activation on set point 2 operation time	ON OFF
C4.4	TIME SET2 60 min	Operation time setting	0 ÷ 60 min
C5.1	OUT1 INPUT ppm	Measure related to the analog output 1	ppm-mg/l °C / °F
C5.2	OUT1 0-20 mA	Range of the analog output 1	0-20 mA 4-20 mA
C5.3	OUT1 POINT P1 0.00 ppm	First point of the analog output 1	Variable
C5.4	OUT1 POINT P2 20.00 ppm	Second point of the analog output 1	Variable
C5.5	OUT2 INPUT ppm	Measure related to the analog output 2	ppm-mg/l °C / °F

Display	Contents	Meaning	Possible values
C5.6	OUT2 0-20 mA	Range of the analog output 2	0-20 mA 4-20 mA
C5.7	OUT2 POINT P1 0.00 ppm	First point of the analog output 2	Variable
C5.8	OUT2 POINT P2 20.00 ppm	Second point of the analog output 2	Variable

<sup>a</sup> = You can change the factory coefficients using the UP and DOWN keys and confirming the value with ENT. To reset the table to factory defaults, simultaneously press the UP, DOWN and ENT.

### Configuration of the input B or input C

The configuration parameters are the same for both inputs.

Display	Contents	Meaning	Possible values
C1.1	MEASURE pH	pH/ORP selection	pH ORP
C1.2	pH SENSOR GLASS	pH sensor type	GLASS ANTIMONY EXT. 4-20 mA
C1.3	RT LARGE SIGNAL 2.0 s	Filter software large	0.4 ÷ 50 s
C1.4	RT SMALL SIGNAL 10.0 s	Filter software small	0.4 ÷ 50 s
C3.1	REGUL. MODE SET1 ON-OFF	Set point 1 regulation type	ON-OFF PID
C3.2	ACTUATION SET1 FM	PID regulation related to set point 1	FM WM
C3.3	SET1 FUNCTION LO	Set point 1 function HI/LO	LO HI
C3.4	REGUL. MODE SET2 ON-OFF	Set point 2 regulation type	ON-OFF PID
C3.5	ACTUATION SET2 FM	PID regulation related to set point 2	FM WM
C3.6	SET2 FUNCTION HI	Set point 2 function HI/LO	LO HI
C4.1	ALARM SET1 OFF	Alarm activation on set point 1 operation time	ON OFF
C4.2	TIME SET1 60 min	Operation time setting	0 ÷ 60 min

Display	Contents	Meaning	Possible values
C4.3	ALARM SET2 OFF	Alarm activation on set point 2 operation time	ON OFF
C4.4	TIME SET2 60 min	Operation time setting	0 ÷ 60 min
C5.1	OUT1 INPUT pH	Measure related to the analog output 1	pH / mV °C / °F
C5.2	OUT1 0-20 mA	Range of the analog output 1	0-20 mA 4-20 mA
C5.3	OUT1 POINT P1 0.00 pH	First point of the analog output 1	Variable
C5.4	OUT1 POINT P2 14.00 pH	Second point of the analog output 1	Variable
C5.5	OUT2 INPUT pH	Measure related to the analog output 2	pH / mV °C / °F
C5.6	OUT2 0-20 mA	Range of the analog output 2	0-20 mA 4-20 mA
C5.7	OUT2 POINT P1 0.00 pH	First point of the analog output 2	Variable
C5.8	OUT2 POINT P2 14.00 pH	Second point of the analog output 2	Variable

## 6.15 DIGITAL OPERATION

The instrument is a slave device that interacts with a master device through the RS485 serial interface.

When connecting to a PC you may need a RS485/RS232 or RS485/USB converter (like the BC model 8701).

The communication takes place via the RS485 connection with the B&C protocols (ASCII) and Modbus RTU (function 03 - 06 -16) described in the following chapters.

When used with the B&C protocol, measurements can be received.

When used with the Modbus protocol, functions 03, 06 and 16 are implemented for reading the measurements and related parameters, changing the set point, alarm and cleaning management parameters.

### 6.15.1 B&C ASCII COMMUNICATION PROTOCOL

Connect the instrument to a PC for data management using a simple terminal emulation program (example Hyperteminal).

#### Transmission mode

Code set	ASCII
Number of bits per character:	
- start bits	1
- data bits	8
- parity	no parity
- stop bits	1
Error check (only A command)	BCC
Speed	9600 baud (default)

#### Commands format

2 bytes of ID transmitter (01 ÷ 32)

1 byte of command

n bytes of data to insert if requested by the command

1 byte <cr> (carriage return), end of the command

 The instrument responds only under the correct received ID or 00.

 Do not use the 00 ID if the instrument is in a network to avoid communication conflicts.

 If the instrument is set to a different speed is not responding.

 *The available commands are listed in the following chapters.*

 *The list of commands implemented in the transmitter is always available by sending the Help command.*

**HELP**

Command format: ID + H <cr>

Example: if ID=14 type 14H <cr> or 00H <cr>

By sending the command H displays the list of available commands with a brief description of their meaning.

```
-----
HELP MENU, COMMAND LIST          B&C ELECTRONICS
-----
CLXX87.103 Rev.fw:1.00  S/N:160589

00H <cr>  Help menu
00A <cr>  Acquisition

Type ID number or 00 before command. Example, if ID=15 type 15A or 00A <cr>
Use 00A <cr> if only one device is connected
-----
```

**ACQUISITION**

Command format: ID + A <cr>

Example: if ID=14 type 14A <cr> or 00A <cr>

By sending the command A, the instrument responds by sending a record containing the code, the ID, date, time, and the value of all the measures.

Record format

```
CLXX87- 01 103 01/01/01 00:00:00 ± 20.00ppm ± 7.00pH ± 460mV ±
...+...|...+...|...+...|...+...|...+...|...+...|...+...|
 20.0°C ± 2.00%/°C ± 0comp ± 9.00pHM ± 20.00ppm ± 0stat
...+...|...+...|...+...|...+...|...+...|...+...|...+...|
 ± 0alar 01/01/01xx
```

CLXX87	p/n of the unit
10	ID
103	p/n extension
0.0	Power voltage (not implemented)
01/01/01	Date (not implemented)
00:00:00	Hour (not implemented)

Below are transmitted the parameter values measured by the unit with the following format:

- Measuring - Sign of measure (if positive is sent a blank)
- Value of measure (6 characters - right alignment)

Measuring unit	- 4 characters - left alignment - 1 blank (ASCII 32)
± 20.00 ppm	Measured value input A
± 14.00 pH	Measured value input B
± 460 mV	Measured value input C
± 20.0 °C	Temperature
± 2.00 %/°C	Temperature coefficient
± 0comp	State of the logic input (0 = open; 1 = close)
± 9.00 pHM	pH value used for free chlorine compensation (pHM = pH manual). 0 = oxidant different from free chlorine or compensation deactivated.
± 20.00 ppm	HOCl value if measuring free chlorine. 0 = oxidant different from free chlorine.
± 0stat	State of the logic input (0 = open; 1 = close) bit0 = logic input 1 state bit1 = logic input 2 state
± 0alar	State of the alarm (0 = no alarm; 1 = alarm) bit0 = input A alarm bit1 = input B alarm bit2 = input C alarm bit3 = alarm set point 1 input A bit4 = alarm set point 2 input A bit5 = alarm set point 1 input B bit6 = alarm set point 2 input B bit7 = alarm set point 1 input C bit8 = alarm set point 2 input C bit9 = logic input 1 alarm bit10 = logic input 2 alarm

At the end of the record the instrument sends the last calibration date, then 2 bytes containing the BCC of the string sent.

10/01/01	Date of the last calibration
xx	2 byte BCC

The record transmission is ended by <cr> <lf>.

### BCC calculation

The BCC messages sent by the transmitter is calculated as the XOR of all the bytes of the message (excluding <cr> and <lf>) and divided into two nibbles.

The two nibbles are then transformed into their ASCII codes.

The BCC transmitted at the end of record is used to check the validity of records received.

### BCC using

The BCC can be used if you want to create a master program that interrogates the instrument.

The BCC is used to check the validity of records received.

## 6.15.2 MODBUS PROTOCOL

On the instrument, in addition to the ASCII B&C protocol, is implemented the Modbus RTU protocol limited to the function 03, 06, and 16.

In Modbus communication network the instrument operates as a slave device.

### RTU transmission mode

Coding system	8-bit binary
Number of bits per character:	
- start bits	1
- data bits (minus sign before)	8
- parity	no parity
- stop bits	1
Errors verification	CRC-16

### RTU messages format

Pause transmission	duration 3,5 bytes
Address	1 byte (8 bits)
Function	1 byte (8 bits)
Data	N bytes (N x 8 bits)
Errors verification	2 bytes (16 bits)
Pause transmission	duration 3,5 bytes

For a correct synchronization of the transmission the receiving unit interprets the end of a message when it doesn't receive any characters (bytes) for a time equivalent to the transmission of 3.5 characters (bytes).

## MODBUS FUNCTION 03

### Function 03 (MASTER QUERY)

Address	1 byte	01 ÷ 243 (instrument ID)
Function	1 byte	03 (read holding register)
Start address data HI	1 byte	Start address of registers
Start address data LO	1 byte	
Number of registers HI	1 byte	Number of registers (2 byte x register)
Number of registers LO	1 byte	

Errors verification	2 bytes	CRC-16
---------------------	---------	--------

The instrument considers valid the message if CRC-16 valid, ID valid and function=03.  
Function 03 (SLAVE ANSWER)

Address	1 byte	01 ÷ 243 (instrument ID)
Function	1 byte	03 (read holding register)
Number of byte of sent data	1 byte	2x number of sent registers
N byte of data	N byte	Values of registers
Error verification	2 bytes	CRC-16

Time between the end of the query and the beginning of the response about 100 ms.  
If an error occurs in the request the response takes the following form:

Address	1 byte	01 ÷ 243 (instrument ID)
Function	1 byte	0x83 (read holding register + error)
Error	1 byte	2 = illegal data address
Error verification	2 bytes	CRC-16

## MODBUS FUNCTION 06 (0x06)

### Function 06 (MASTER QUERY)

Address	1 byte	1 ÷ 243 (probe ID)
Function	1 byte	06 (write single register)
Address data HI	1 byte	Address of the register
Address data LO	1 byte	
Value of the register HI	1 byte	Value to be written
Value of the register LO	1 byte	
Errors verification	2 bytes	CRC-16

The probe considers valid the message if CRC-16 valid, ID valid and function=06.

### Function 06 (SLAVE ANSWER)

Address	1 byte	1 ÷ 243 (probe ID)
Function	1 byte	06 (write single register)
Address data HI	1 byte	Address of the register
Address data LO	1 byte	
Value of the register HI	1 byte	Value to be written
Value of the register LO	1 byte	
Errors verification	2 bytes	CRC-16

If an error occurs in the request, the response takes the following form:

Address	1 byte	1 ÷ 243 (probe ID)
Function	1 byte	0x86 (write single register + error)
Error	1 byte	2 = illegal data address 3 = illegal data value 6 = device busy
Error verification	2 bytes	CRC-16

## MODBUS FUNCTION 16 (0x10)

### Function 16 (MASTER QUERY)

Address	1 byte	1 ÷ 243 (probe ID)
Function	1 byte	16 (write multiple registers)
Start address data HI	1 byte	Start address of registers
Start address data LO	1 byte	
Number of registers HI	1 byte	Number of registers (2 byte x register)
Number of registers LO	1 byte	
Number of byte	1 byte	2 byte per register
Value of registers	n byte	n = 2 byte x number of registers
Errors verification	2 bytes	CRC-16

The probe considers valid the message if CRC-16 valid, ID valid and function=16.

### Function 16 (SLAVE ANSWER)

Address	1 byte	1 ÷ 243 (probe ID)
Function	1 byte	16 (write multiple registers)
Start address data HI	1 byte	Start address of registers
Start address data LO	1 byte	
Number of registers HI	1 byte	Number of registers (2 byte x register)
Number of registers LO	1 byte	
Errors verification	2 bytes	CRC-16

If an error occurs in the request, the response takes the following form:

Address	1 byte	1 ÷ 243 (probe ID)
Function	1 byte	0x90 (write multiple registers + error)
Error	1 byte	2 = illegal data address 3 = illegal data value 6 = device busy
Error verification	2 bytes	CRC-16

## MODBUS REGISTERS

The measurement and status data of the instrument are available from the address 0x0000 and can be searched using function 03.

The data relating to the setting of the set-points, the alarm limits and the activation of the cleaning cycle are available from the address 0x0200 and can be modified through function 06 or 16.

Time between the end of the query and the beginning of the response about 100 ms.

### DATA THROUGH MODBUS FUNCTION 03

	Modbus address	Parameter	Range	Unit	Scale
1	0x0000	Oxidants scales	-100 ÷ 2100	a	a
2	0x0001	Oxidants scale	1 ÷ 5	1	b
3	0x0002	pH (input 1)	-100 ÷ 1500	0.01 pH	0.00 ÷ 14.00 pH
4	0x0003	ORP (input 1)	-2100 ÷ 2100	1 mV	-2000 ÷ 2000 mV
5	0x0004	Scale input 1	1 ÷ 2	1	1 = pH ; 2 = ORP
6	0x0005	pH (input 2)	-100 ÷ 1500	0.01 pH	0.00 ÷ 14.00 pH
7	0x0006	ORP (input 2)	-2100 ÷ 2100	1 mV	-2000 ÷ 2000 mV
8	0x0007	Scale input 2	1 ÷ 2	1	1 = pH ; 2 = ORP
9	0x0008	Temperature °C	-100 ÷ 1100	0.1	-10.0 ÷ 110.0 °C
10	0x0009	Temperature °F	140 ÷ 2300	0.1	14.0 ÷ 230.0 °F
11	0x000A	Temp. Coeff.	0 ÷ 400	0.01	0.00 ÷ 4.00 %/°C
12	0x000B	Comp. Cl2 F	0 ÷ 2	1	0=OFF ; 1=MAN 2=AUTO
13	0x000C	pH for man. comp. Cl2 F	-100 ÷ 1500	0.01 pH	0.00 ÷ 14.00 pH
14	0x000D	HOCl value	-100 ÷ 2100	a	a
15	0x000E	Logic input state	0 ÷ 4	1	See table 1 below
16	0x000F	Alarm state	0 ÷ 1024	1	See table 2 below
17	0x0010	BCC EEPROM	0 ÷ 65535	1	0 ÷ 65535

<sup>a</sup> = unit and scale depend on what is set in configuration

<sup>b</sup> = see chapter "Technical specification (page 23)"

Data format is integer signed (-32768/+32767).

<b>Table 1 Logic input state</b> 0 = input open 1 = inpute closed	
bit 0	Logic input 1
bit 1	Logic input 2

<b>Table 2 Alarm state</b> 0 = alarm deactivated 1 = alarm active	
bit 0	alarm input A
bit 1	alarm input B
bit 2	alarm input C
bit 3	alarm set point 1 input A

<b>Table 2 Alarm state</b> <b>0 = alarm deactivated</b> <b>1 = alarm active</b>	
bit 4	alarm set point 2 input A
bit 5	alarm set point 1 input B
bit 6	alarm set point 2 input B
bit 7	alarm set point 1 input C
bit 8	alarm set point 2 input C
bit 9	alarm logic input 1
bit 10	alarm logic input 2

**SET POINT - ALARM - CLEANING MANAGEMENT PARAMETERS (address 0x020x)**

	<b>Modbus address</b>	<b>Parameter</b>	<b>Range</b>	<b>Unit</b>	<b>Scale</b>	<b>Data type</b>	<b>R/W</b>
1	0x0200	Set 1 IN A	a	b	b	IS	R/W
2	0x0201	Set 2 IN A	a	b	b	IS	R/W
3	0x0202	Set 1 IN B	a	b	b	IS	R/W
4	0x0203	Set 2 IN B	a	b	b	IS	R/W
5	0x0204	Set 1 IN C	a	b	b	IS	R/W
6	0x0205	Set 2 IN C	a	b	b	IS	R/W
7	0x0206	Alarm LO IN A	a	b	b	IS	R/W
8	0x0207	Alarm HI IN A	a	b	b	IS	R/W
9	0x0208	Alarm LO IN B	a	b	b	IS	R/W
10	0x0209	Alarm HI IN B	a	b	b	IS	R/W
11	0x020A	Alarm LO IN C	a	b	b	IS	R/W
12	0x020B	Alarm HI IN C	a	b	b	IS	R/W
13	0x020C	Clean -Relé3 clean  -start cycle	0x8001 = not associated or not enabled 1 = associated and enabled  1 = clean start only if associated, enabled and no local action in progress			IS	R  W

<sup>a</sup> = range depends on what is set in the configuration / 0x8001 = non-settable set point (assigned to another function)

<sup>b</sup> = range, unit and scale depend on what is set in the configuration

IS = integer signed / I = integer

R = read / W = write

**Use of BCC EEPROM]**

The EEPROM BCC check is the probe configuration state synthesis. After setting the parameters and carry out the calibration the value of the BCC remains constant until the next change of parameters or calibration.

A variation of BCC in the absence of changes warns that an alteration has taken place in the probe configuration data.

# 7 INSTALLATION DRAWINGS

## 7.1 CONNECTION DIAGRAM

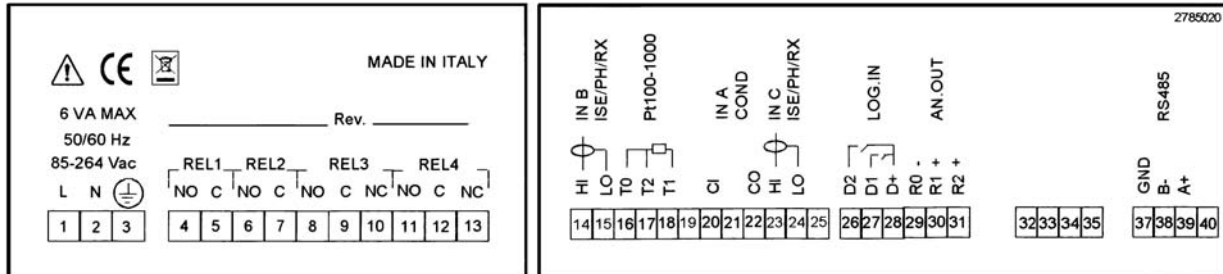

Terminal	Function	Terminal	Function
1	Power supply 85/264 Vac	14	Input B ISE/pH/ORP electrode
2	Power supply 85/264 Vac	15	Input B reference electrode
3	Ground	16	Common temperature sensor input
4	NO relay 1	17	Common temperature sensor input
5	C relay 1	18	Temperature sensor input
6	NO relay 2	20	Input A conductivity probe
7	C relay 2	22	Input A conductivity probe
8	NO relay 3	23	Input C ISE/pH/ORP electrode
9	C relay 3	24	Input C reference electrode
10	NC relay 3	26	Logic input 2
11	NO relay 4	27	Logic input 1
12	C relay 4	28	Common logic inputs
13	NC relay 4	29	- Analog outputs (common)
		30	+ Analog output 1
		31	+ Analog output 2
		37	RS485 Gnd
		38	RS485 B-
		39	RS485 A+

## 7.2 DIMENSIONS AND INSTALLATION

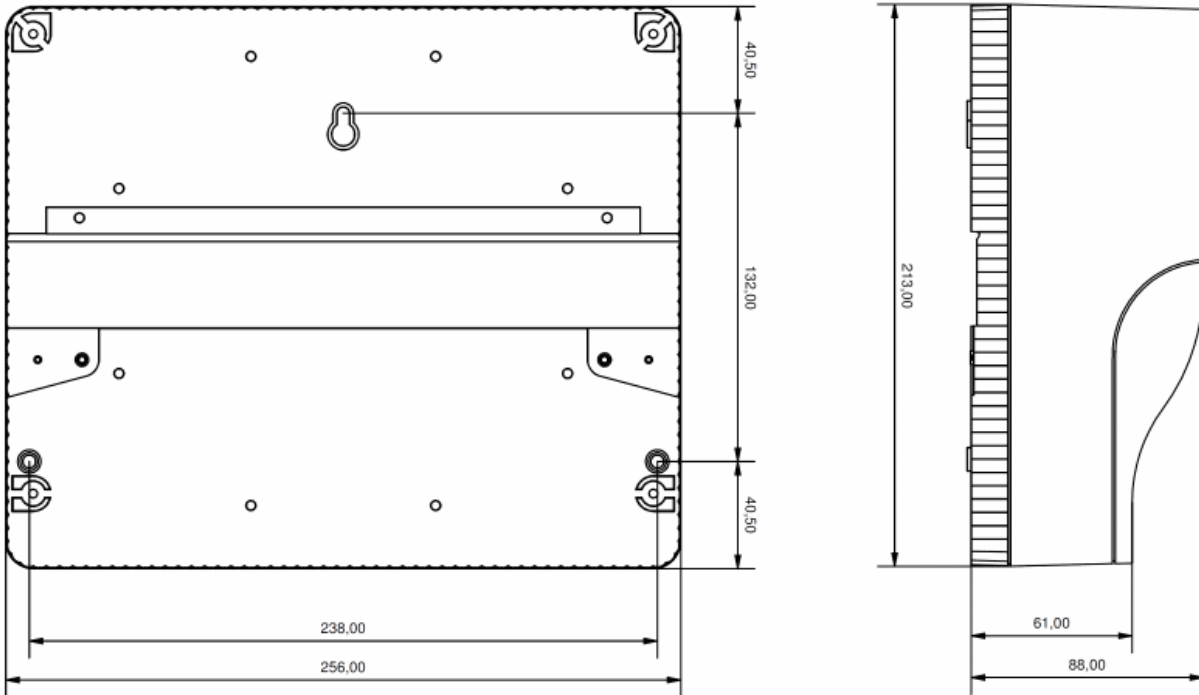

*Fig. 1 Dimensions*

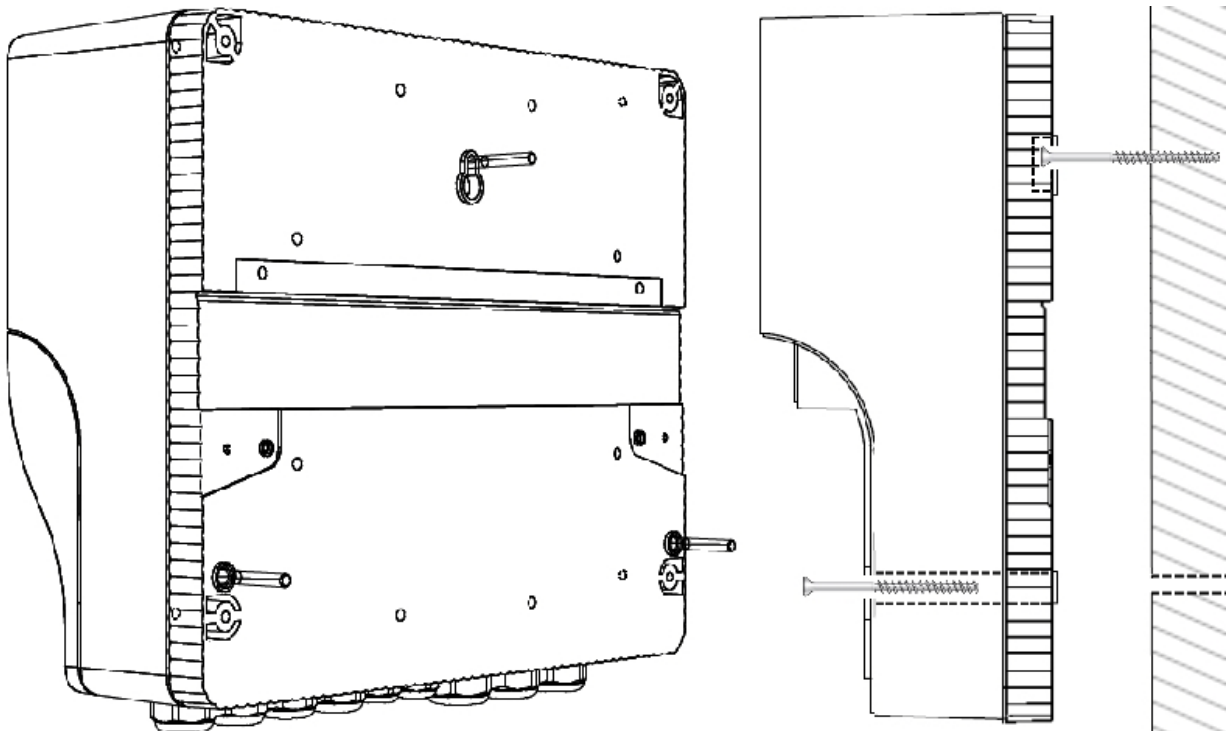

*Fig. 2 Wall mounting*

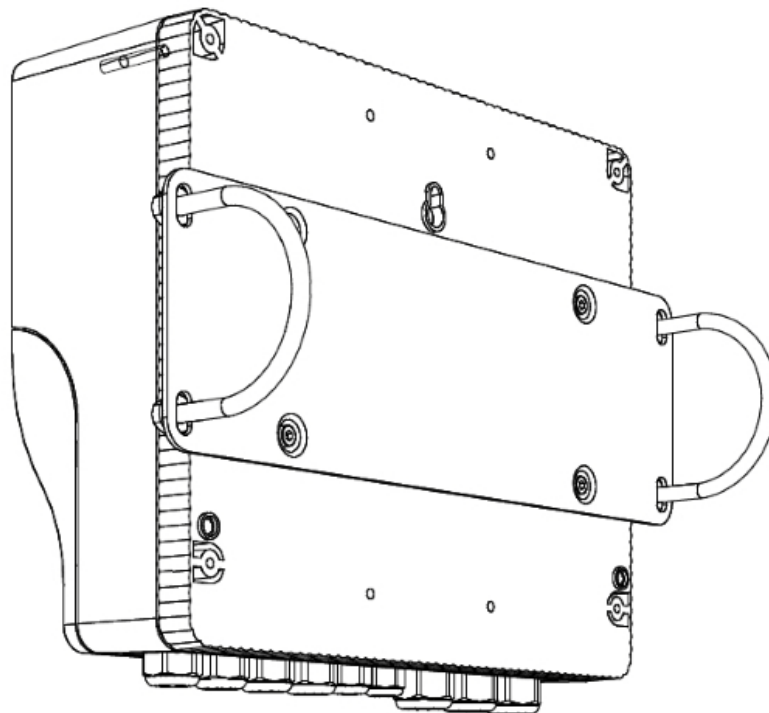

*Fig. 3 Pipe mounting (horizontal or vertical)*

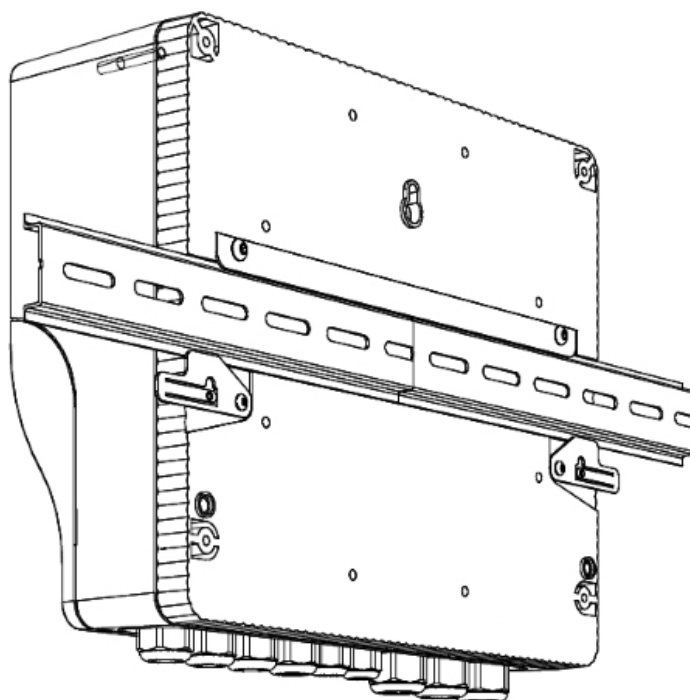

*Fig. 4 Rail-DIN mounting*

## 8 WARRANTY

- 1 Your product is guaranteed for 5 years from the date of purchase, for failure due to manufacturing defects.
  - 2 The warranty is void in case of tampering or deterioration due to improper installation or maintenance.
  - 3 The warranty covers only free repair at the laboratories of the manufacturer.
  - 4 B&C Electronics is not liable for any damage arising from misusing its instruments and products.
- 

## 9 REPAIRS

For faster and efficient service it is recommended to fill in the "Information card" for the repair service and attach it to a "Repair order".

- 1 The estimated cost, if required by the customer, is free if the repair is confirmed. Otherwise flat rate results in a charge for the analytical work performed and expenses incurred.
- 2 The products to be repaired must be sent to B&C Electronics with freight prepaid. Any expenses incurred on behalf of the client and not previously agreed will be charged.
- 3 Our sales department will submit to the customer the repair estimate or offer a replacement in the following cases:
  - repair cost is considered excessive in relation to the cost of the product;
  - the repair is technically impossible or unreliable.
- 4 In order to reduce the time of delivery of the repaired products, unless otherwise offered or arranged by the customer, the shipment will be made with ex-factory, prepaid carriage by a courier.

INFORMATION SHEET  
*for service repairs*

In the event of a fault, we recommend you contact our repair service, to photocopy and complete this information sheet to be attached to the product to be repaired.

ESTIMATE

REPAIR

---

COMPANY NAME

---

ADDRESS

ZIP

TOWN

---

REFER TO MR/MRS

TELEPHONE

---

MODEL

S/N

DATE

---

Consult the instruction manual to identify the area of the defect and/or describe it:

SENSOR

ANALOG OUTPT

POWER SUPPLY

SET POINT

CALIBRATION

RELAYS CONTACTS

DISPLAY

INTERMITTENT PROBLEM

---

DESCRIPTION OF THE DEFECT

. . . . .

. . . . .

. . . . .

. . . . .

. . . . .

. . . . .











**B&C Electronics s.r.l. – Via per Villanova 3 – 20866 Carnate (MB) – Italia**  
Tel. +39 039 631 721 – Fax +39 039 607 6099 – [bc@bc-electronics.it](mailto:bc@bc-electronics.it) – [www.bc-electronics.it](http://www.bc-electronics.it)